

SERVICE MANUAL

-Controller and Accessory

Infrared controller:

- YR-H71.....Page 1
- YR-H65.....Page 12
- YR-H50.....Page 13
- YR-H49.....Page 13

Address set controller:

- ASC-002.....Page 14

Wired controller:

- YR-E06.....Page 15
- YR-E12.....Page 24

Central controller:

- YCZ-A001.....Page 29
- ICR01.....Page 34

Weekly timer:

- YCS-A001.....Page 40

Detector:

- YCJ-001.....Page 46
- IGU04.....Page 57



1.1 Infrared controller YR-H71

Caution: YR-H71 has code A and code B, for code B, controller hasn't swing etc. functions ,and after changing batteries ,code B will be reset to code A.

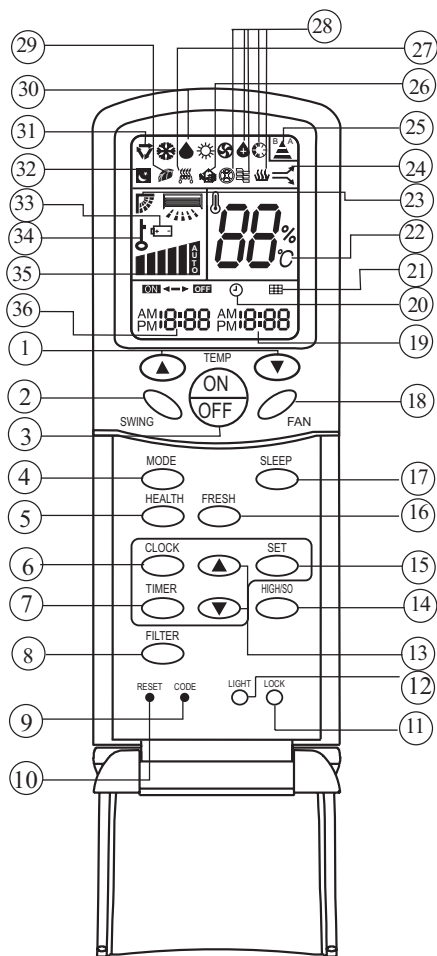

1.TEMP Setting Button

(Used to set temperature. Setting ranges: 16°C to 30°C)

In Up/Down function, for controlling up and down filter.

2.SWING Button

If you press this button once, auto swing will be activated.

If you press this button again, the louver will fix in the present position.

3.Power ON/OFF Button

Used for unit start and stop

After power on, the LCD of remote controller will display the previous operation state (except for TIMER,SLEEP and SWING state).

NOTE: 1.Cooling only air conditioner does not have the displays and functions related to heating.

2.HIGH/SO button

This button is activated in Cooling/Heating mode, the fan speed is in AUTO mode after pressing it and "high functon" will be cancelled automatically after 15 minutes running.

4.Operation MODE

Used to select operation mode.

Every time you press MODE button, operation mode changes according to following sequence:



5.HEALTH Button

Used to set health mode, if the unit has the negative ion function and oxygen bar function.

6.CLOCK Button

Used to set correct time.

7.CLOCK Button

Used to select TIMER ON, TIMER OFF.

(Note: if time of TIMER ON is the same as TIMER OFF,TIMER ON/OFF cannot be set)

8. FILTER Button

Used to set up/down function of filter.

9. CODE Button

Used to select code A or B, for the units except that we recommend especially, the code is A.

10.RESET Button

Press this button by using a sharp article to resume the correct operation of the remote controller in case of need, i.e. for example in case of malfunctions due to electromagnetic noise.

11.LOCK Button

Used to lock operation button and LCD display contents: by pressing this button, other buttons comes out of function and lock state display appears; if you press it again, lock state will be no more active and lock state display will disappear.

12.LIGHT Button

Used to light the control panel (only for cabinet unit)

13.Up and down Button

Used to set TIMER and CLOCK up or down.

14.HIGH/SO Button

Used to select HIGH or SOFT operation.

15.SET Button

Used to confirm TIMER and CLOCK settings.

16.FRESH Button

Used to set fresh mode, the unit will draw in fresh air.

17.SLEEP Button

(The clock must be corrected before setting sleep function) Used to set sleep mode.

18.FAN Button

Used to select fan speed:LOW,MID,HIGH,AUTO.

19.TIMER OFF Display

20.CLOCK Display

21.FILTER Display

22.TEMPERATURE Display

23.AUTO SWING Display

24.HIGH/SO Display

25.SIGNAL SENDING Display

26.FRESH AIR Display

27.ELECTRICAL HEATING Display

28.Some other buttons

All these functions are not available now.

29.HEALTH Display

Displays when healthy run function is set.

30.DEHUMIDIFICATION Display

31.Operation MODE Display

AUTO RUN	COOL RUN	DRY RUN	HEAT RUN	FAN RUN

32.SLEEP State Display

33.BATTERY Energy Display

Notify the user when it is time to change the batteries.

34.LOCK State Display

35.FAN SPEED Display

LO		
MID		
HI		
AUTO		

36.TIMER ON Display

Remote Controller' Operation

- When in use, direct signal transmission head to the receiver placed on the indoor unit

- The distance between the remote controller and the receiver should be max 7m and there should be no obstacle between them.
- Do not throw the remote controller; prevent it from being damaged.
- When operating the remote controller in an area where electronically controlled lights are installed or wireless handsets are used, please move closer to the indoor unit as the function of the remote controller might be affected by signals emitted by the above mentioned equipments.

Battery loading

Battery loading

Batteries are fitted as follows:

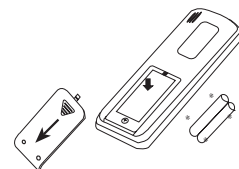

Remove the battery compartment lid Slightly press and disengage the battery compartment lid marked with "▼" and then hold the remote controller by the upper section and then remove the battery compartment lid by pressing in the direction of the arrow as shown in the figure above.

Loading the battery

Ensure that batteries are correctly placed in the compartment as required for positive and negative terminals.

Replacing the battery compartment lid

The battery compartment lid is reinstalled in the reverse sequence.

Display review

Press the button to see if batteries are properly fitted. If no display appears, refit the batteries.

Confirmation indicator

If no indication is displayed after press ON/OFF button, reload the batteries.

Caution:

If the remote controller does not operate as designed after fitting new batteries of the same type, press the Reset button (marked ↓) with a pointed article.

Clock Set

When unit is started for the first time and after replacing batteries in remote controller, clock should be adjusted as follows:

- 1.Press CLOCK button, clock indication of " AM " or " PM " flashes.
- 2.Press ▲ or ▼ to set correct time. Each press will increase or decrease 1 min. If the button is kept pressed, time will increase or decrease quickly.
- 3.After time setting is confirmed, press "SET" : AM or PM stop flashing, while clock starts working.

Note:AM means morning and PM means afternoon.

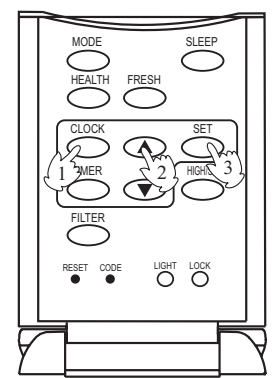

Note:

It is recommended that the batteries be removed from the compartment if the remote controller is not used for an extended period.

The remote controller is programmed for automatic test of operation mode after the batteries are replaced. When the test is conducted, all icons will appear on the screen and then disappear if the batteries are properly fitted.

Fan Operation

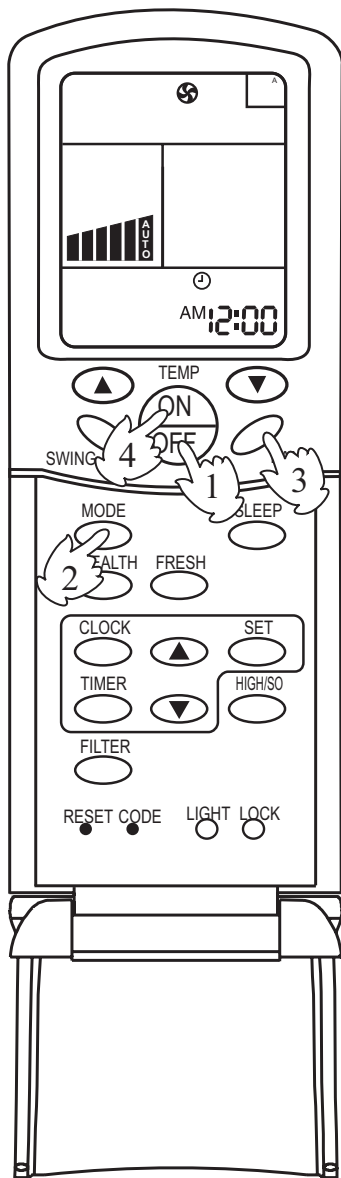

1. Unit start

Press ON/OFF button to start your air conditioner.

Previous operation status appears on LCD (except for TIMER, SLEEP, and SWING setting).

2. Select operating mode

Press MODE button. At each press, operation mode changes as follows:



Then **select FAN**

3. Adjust fan speed

Press FAN button. At each press, fan speed changes as follows:



Air conditioner will run at the selected fan speed.

When in AUTO mode, unit will adjust fan speed according to room temperature automatically.

4. Unit stop

Press ON/OFF button to stop unit.

About FAN mode

When the air conditioner runs in FAN mode, it is not possible to select AUTO FAN or to set temperature.

AUTO, COOL, HEAT and DRY Operation

1. Unit start

Press ON/OFF button, unit starts.

Previous operation status appears on LCD (except for TIMER, SLEEP and SWING setting)

2. Select operation mode

Press MODE button. At each press, operation mode changes as follows:



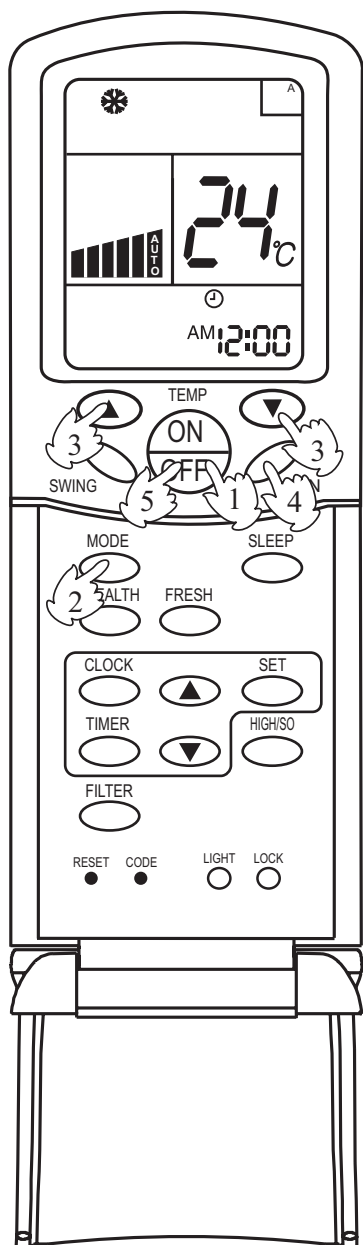

Then or or
 or

3. Temperature setting

Press TEMP button.

- ▲ Every time the button is pressed, temp. setting increases 1°C; if the button is kept pressed, temp. setting will increase quickly.
- ▼ Every time the button is pressed, temp. setting decreases 1°C, if the button is kept pressed, temp. setting will decrease quickly.

Set proper temperature

4. Adjust FAN button

Press FAN button. At each press, fan speed changes as follows:



Air conditioner will run at the selected fan speed.

5. Unit stop

Press ON/OFF button, unit stops.

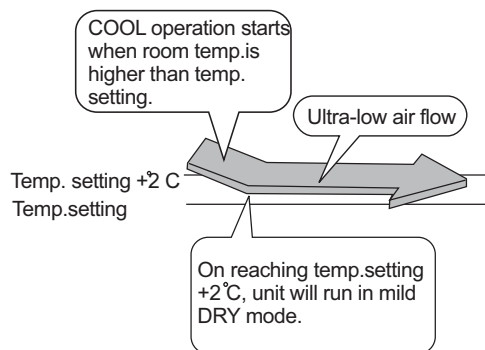

In ATUO mode, the temperature setting is not displayed on LCD. In this mode, during running air conditioner will select COOL, HEAT or FAN mode automatically according to the room temperature.

In DRY mode, when room temperature becomes 2°C higher than temperature setting, unit will run intermittently at LOW speed regardless of FAN setting. When room temperature is lower than temperature setting, unit will only run FAN operation.

In HEAT mode, warm air will blow out after a short period of time due to cold-draft prevention function.

Adjusting air flow direction

AUTO SWING

Press SWING button. Up and down airflow varies upwards and downwards. Left and right airflow varies left and right sides. When the automatic swing louver moves to the proper angle, press SWING button can fix the airflow direction.

- Always use SWING button on the remote controller to adjust flaps. Adjusting them by hand may result in air conditioner's abnormally running.

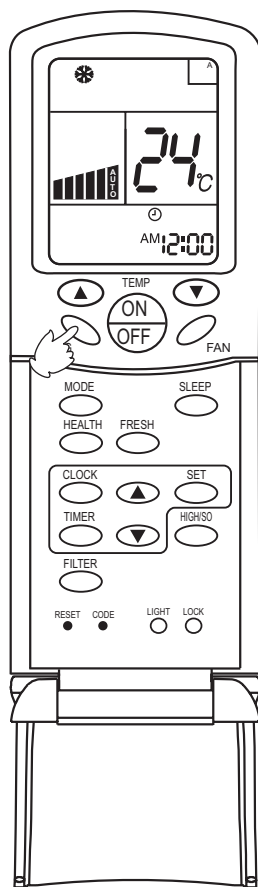

- In COOL or DRY mode, do not leave the louver in downward position for a long time, as the water vapor close to the grille may condense and water may drop from the air conditioner.
- Please carefully set temperature when children, old or weak people use the air conditioner.
- In case of great humidity, If the vertical flaps are completely turned towards left or right, the louver will drop water.
- Never adjust the louver directly by hand, as this could make it work abnormally. If the louver work abnormally, stop unit, restart and adjust the louver by remote controller.

After unit stops:

Displays on the LCD disappear.

All indicators on the indoor unit go out.

Swing louver automatically close the air outlet.

Hints:

As in COOL mode air flows downwards, adjusting airflow horizontally will be much more helpful for a better air circulation. As in HEAT mode air flows upwards, adjusting airflow downward will be much more helpful for a better air circulation. Be careful not to catch a cold when cold air blows downward directly.

Sleep Function

Before going to bed you can press down the SLEEP button and the air conditioner will run so as to make you sleep more comfortably. Before using this function, the clock must be set.

Use of SLEEP function

After the unit's start, set running mode and then press SLEEP button once to make the air conditioner have the previous-set sleep time (first power-on is "1h"). The sleep symbol will appear.

▲/▼: Press time button, you can choose the time in 1~8 hours. Each time the button is pressed, the time increases/decreases 1 hour: "xh" and "OFF" indications appear on the display.

Operation Mode

1. In COOL, DRY mode

One hour after sleeping operation start, the temperature is 1°C higher than the setting one. After another hour, temperature rises 1°C: sleep run continuously for another 6 hours and then stops. The actual temperature is higher than the setting one which is to prevent from being too cold to your sleep.

2. In HEAT mode

One hour after sleeping operation start, the temperature is 2°C lower than the setting one. After another hour, temperature decreases by 2°C more. Temperature will automatically rise by 1°C after another 3 hours' continuous operation. The actual temperature is lower than the setting one which is to prevent from being too hot to your sleep.

3. In AUTO mode.

The air conditioner will run in corresponding sleep operation according to the automatically selected operation mode.

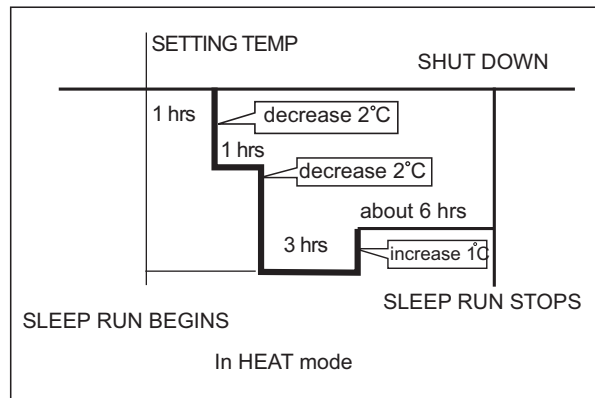
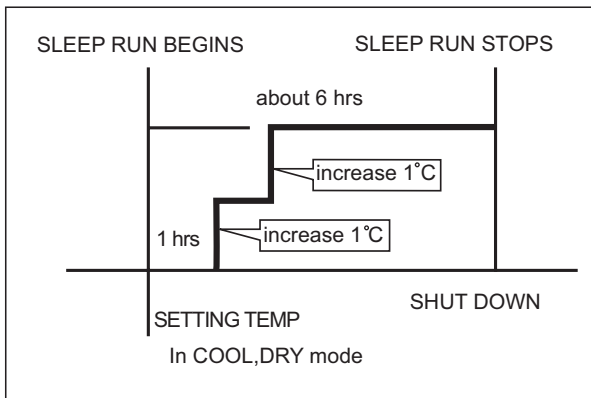

Notes:

- After setting SLEEP function, it is not possible to set clock.
- If set-sleep time does not reach 8 hours, unit will automatically stop operation after set time is reached.
- Set "TIMER ON" or "TIMER OFF" in COOL, DRY mode function first, then set SLEEP. After set SLEEP function, the TIMER function cannot be set.

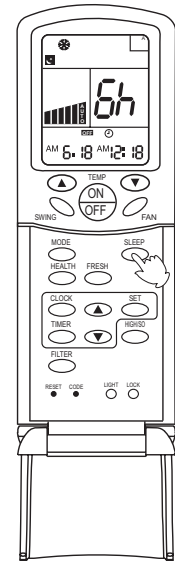

Timer ON/OFF Function

Set clock correctly before starting TIMER operation

1. Unit start

After unit start, select your desired operation mode (operation mode will be displayed on LCD)

2. TIMER mode selection

Press TIMER button on the remote controller to change TIMER mode. Every time the button is pressed, display of TIMER mode changes as follows:

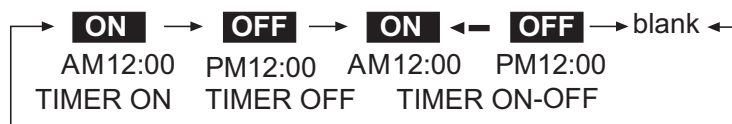

Then select TIMER mode as needed (TIMER ON or TIMER OFF).

Now **ON** or **OFF** will flash.

3. TIMER setting (press time adjust buttons ▲ ▼)

▲ Every time the button is pressed, time increases 10 minutes. If the button is kept pressed, time changes quickly.

▼ Every time the button is pressed, time decreases 10 minutes. If the button is kept pressed, time changes quickly. It can be adjusted within 24 hours at will.

4. Confirm setting

After setting correct time, press SET button to confirm time. Now **ON** or **OFF** stop flashing.

Time displayed: unit starts or stops at X hour X min (TIMER ON or TIMER OFF)

5. Cancel TIMER mode

Just press TIMER button several times until TIMER mode disappears.

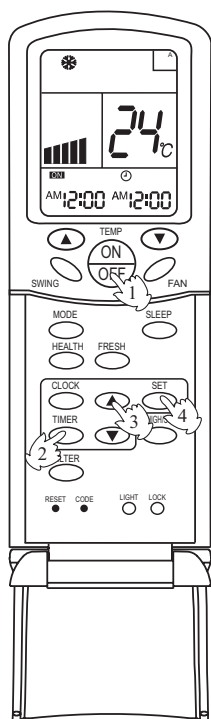

Hints:

After replacing batteries or if a power failure occurs, TIMER setting must be reset. Remote controller has memory function. When you use TIMER mode next time, just press SET button after mode selection if timer setting is the same as the previous one.

Note:

After setting TIMER function, the remote controller displays TIMER time. If you want to see clock time, just press CLOCK button once: clock time will be displayed (if you press the button again continuously, you can adjust clock). 5 seconds later, the display will show TIMER time again.

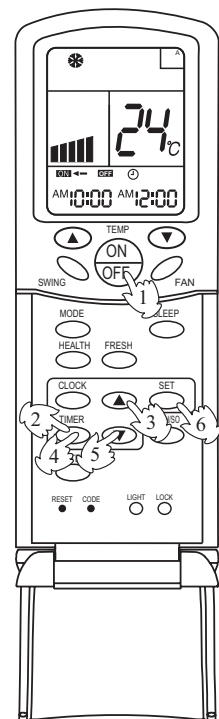

Timer ON-OFF Function

Set clock correctly before starting TIMER operation

1. Unit start

After unit start, select your desired operation mode (operation mode will be displayed on LCD)

2. TIMER mode selection

Press TIMER button on the remote controller to change TIMER mode. Every time the button is pressed, display of TIMER mode changes as follows:

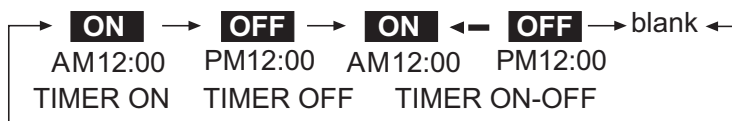

Then select TIMER ON-OFF mode. **ON** will flash.

3. Time setting for TIMER ON

Press time button \blacktriangle

- \blacktriangle Every time the button is pressed, time increases 10 minuts. If the button is kept pressed, time will changes quickly.
- \blacktriangledown Every time the button is pressed, time decreases 10 minuts. If the button is kept pressed, time will changes quickly. It can be adjusted within 24 hours at will. AM refers to morning and PM refers to afternoon.

4. Timer confirming for TIMER ON

After setting correct time, press TIMER button to confirm time. Now **ON** stops to flash, while **OFF** starts flashing. Time displayed : unit starts at X hour X min.

5. Timer setting for TIMER OFF

Press time buttons \blacktriangle and follow the same procedures in " Time setting for TIMER ON"

6. Time confirming for TIMER OFF

After time setting, press SET button to confirm time. **OFF** stops to flash. Time displayed: unit starts at X hour X min.

7. Canel TIMER mode

Just press TIMER button several times until TIMER mode disappears. According to the time setting sequence of TIMER ON and TIMER OFF, either start-stops or stops-start can be realized.

If the time setting of TIMER ON is the same as TIMER OFF, TIMER ON-OFF function cannot be set.

Filter Up/Down

(Only for 600*600 panel of single unit)

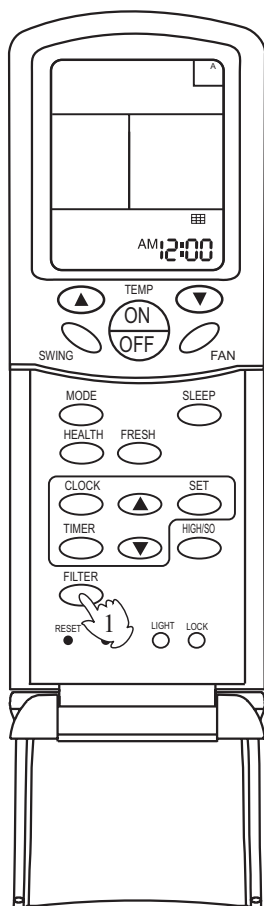

After the air conditioner has operated for a certain period, dust has accumulated on the filter, and the filter up/down function can be used to clean it.

1. Whether unit starts or stops, continuously press FILTER button for 3 seconds, and enter the filter up/down waiting status (when unit stops, the yellow TIMER indicator flashes, and filter and clock indication are displayed on the remote controller. Only the FILTER button, the temperature buttons "▲" "▼" and time buttons ▲ ▼ are active).

2. Press temperature "▼" button or time "▼" button in filter up/down waiting status: the up/down mechanism makes the filter moving downward and does not stop until it has reached the maximum limit.

3. Press temperature "▲" button or time "▲" button in filter up/down waiting status: the up/down mechanism makes the filter to moving upward till near the surface board and then automatically adjusts it to reset (when adjusting to reset, it will not be controlled by the remote controller till the adjustment is finished).

4. During moving downward, press temperature "▲" button or time "▲" button: moving stops.

5. During moving downward, press temperature "▼" button or time "▼" button: moving stops.

6. Continuously press FILTER button 3 seconds again to cancel the filter up/down waiting mode (unit stops, the yellow timer indicator stops flashing, the filter goes back to the original position, the remote controller goes back to off status and only clock is displayed).

Note:

If the filter does not thoroughly go back to the original position, only needs to operate several times repeatedly.

" High mode " Operation

Outline of operation in "High Mode"

This function is suitable when the set temperature must be reached in the shortest delay. The button "HIGH/SO", referred to this function, is effective in Cooling/Heating mode (not in Auto/Dry/Fan modes).

NOTICE:

- When the air conditioner is operating in " High Mode " , unevenness of room air temperature may occur due to the intensive operation in a short time.
- Anyway, operation in "High Mode", does not last for more than 15 minutes, then regular operation is automatically restored.

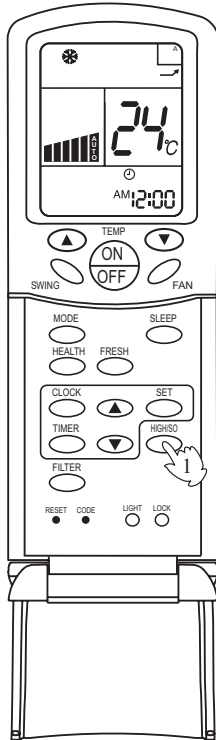

ON

Press the HIGH/SO button once

The indication  appears on the display of the remote controller and operation in "High Mode" starts.

The AUTO fan speed is automatically set and the corresponding indication is also displayed.

OFF

Press the HIGH/SO button twice

If the button is pressed once, the indication  is displayed on the remote controller. If you press the button once again, the indication disappears, regular operation is restored and fan speed goes back to the mode set before "High Mode" operation.

" Soft mode " Operation

Outline of operation in "Soft Mode"

Operation in "Soft Mode", more silent, is suitable when noises should be reduced, e.g.. for reading or sleeping. The button "HIGH/SO", referred to this operation, is effective in Cooling/Heating mode (not in Auto/Dry/Fan modes).

ON

Press the HIGH/SO button twice

The indication  appears on the display of the remote controller and operation in "Soft Mode" starts. The AUTO fan speed is automatically set and the corresponding indication is also displayed.

OFF

Press the HIGH/SO button twice

If the button is pressed once, the indication  is disappears from the remote controller's display. If you press the button once again, regular operation is restored and fan speed goes back to the mode set before "Soft Mode" operation.

NOTICE:

- When the air conditioner is operating in " High Mode " , unevenness of room air temperature may occur due to the intensive operation in a short time.
- Anyway, operation in "High Mode", does not last for more than 15 minutes, then regular operation is automatically restored.

Auto restart function setting

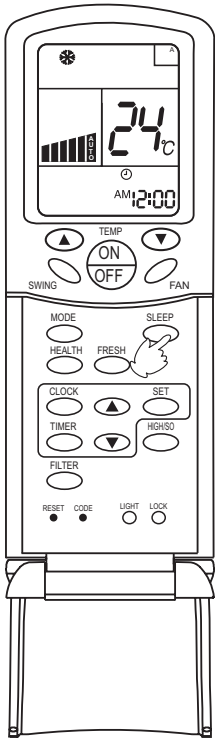

After the power failure compensation is set, if power failure suddenly occurs while the air conditioner is working, it will resume the previous working state when the power is supplied again.

Setting Method: When the remote controller is on (excluding timer mode and fan mode), press the "Sleep" button on the remote controller 10 times within 5 seconds, and after the buzzer rings 4 times, the air conditioner will enter the state of auto restart.

Cancel Method: Press the "Sleeping" button on the remote controller 10 times within 5 seconds, and after the buzzer rings 2 times, the auto restart mode will be cancelled.

Notes: When a power failure suddenly occurs during the air conditioner is working after the power failure compensation is set, if the air conditioner will not be used for a long time, please cut off the power supply to prevent its operation from being resumed after the power is supplied again, or press the "Switch On/Off" button after the power comes again.

If the unit has not the "sleep" button or function, please realize the function by pressing "swing" with the same method.

Note:

This kind of remote controller can be used for all UNITARY FREE indoor units except for AP182ACBEA.

Infrared controller YR-H71 and remote receiver RE-01:

If the unit is wired type and it is without the remote receiver, you can use the remote receiver RE-01 and the remote controller YR-H71 to realize the remote function. The installation of remote receiver and usage function are as follows:

The right figure is a remote controller, which can be used on series remote control units and the matching remote control receiver

1. Remote control receiver using method :

Use remote controller control the remote control window of the remote control receiver.

2. For Unitary Free and Free Multi units, the controller CODE please select code "A"; for H-MRV and ASX ABAA unit, please select code "B".**

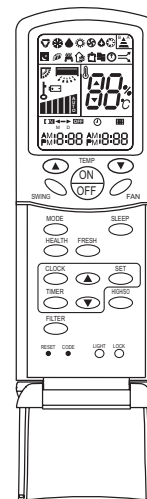
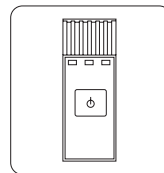
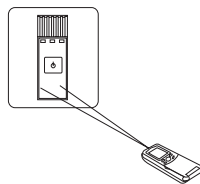

Remote receiver Remote controller

Installation of receive display

Because of the temperature sensitive device, do not install the receive display at straight sunlight place, either in front of air outlet grill, for it is effected greatly from cool air and heat air, the receive display is at least 20mm distance to the air outlet grill.

Since there is light sensitive device which receives wireless remote signal, so do not installed behind the window curtain or other obstacles, in order not to obstruct the signal.

Must fix the remote control wire far from strong electricity (such as the wiring of electric light, air conditioner, etc.) and weak electricity (such as the wiring of telephone, interphone, etc.).

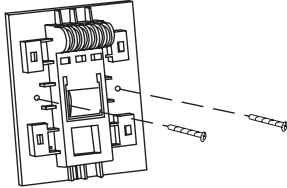

1. Fix the receive display with screws on the selected place

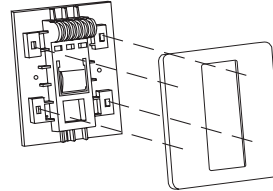

2. Place the panel onto the fixed frame, pay attention that the four claws must be placed into the corresponding four poles on the frame

Connecting wiring method of receiver :

- Refer the indoor unit wiring diagram .
- Safety cautions see the electrical wiring part .

- ①. Emergency switch
- ②. Running lamp: When the compressor working, this lamp bright.
- ③. Timing lamp: When the unit been setting Timing running, this lamp bright.
- ④. Power lamp: After open the unit, this lamp bright when the unite enter health running, the lamp change from orange to blue lamp.
- ⑤. Indoor temp. sensor: Test the room temperature.

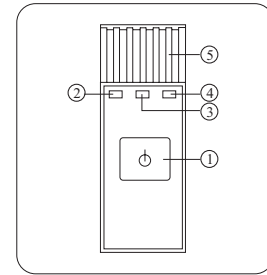

1.2 Infrared controller YR-H65

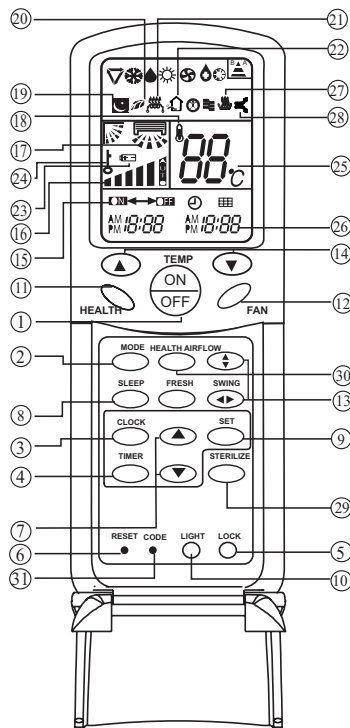

Except [swing][Health Aireflow][Sterilize] function, the other basic functions are same with YR-H71, please reference YR-H71 manual.

⑬ [Swing] function description:

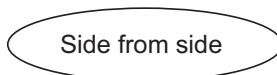

Swing

- Press SWING the vertical louvers move from side to side.

Fixed position

- Press the SWING again to fix the vertical louvers at your desired position.

Swing

- Press SWING the horizontal louvers move from up to down.

Fixed position

- Press the SWING again to fix the horizontal louvers at your desired position.

Note: Put louvers at up position in cooling and down position in heating mode. This will be helpful to keep an even room temp.

Notice: In cooling or dry operation, don't put horizontal louvers at downward position for a long time, or outlet grill might get frosted. Don't expose your skin to cool or warm air for a long time.

- ②⑨ STERILIZE
(This function is optional)
- ③⑩ HEALTHAIRFLOW
Used to set healthairflow

Notice: For remote type units, remote controller doesn't display error code, in the indoor unit, there is a error lamp in display board, the error lamp will flash and tell you what trouble it's happening.

1.3 Infrared controller YR-H50

The main functions of YR-H50 are same with YR-H65, please reference YR-H71 and YR-H65 manuals.

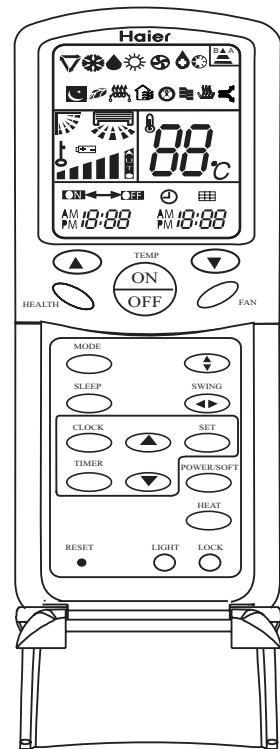

1.4 Infrared controller YR-H49

Please reference YR-H71 operation manual to use the controller.

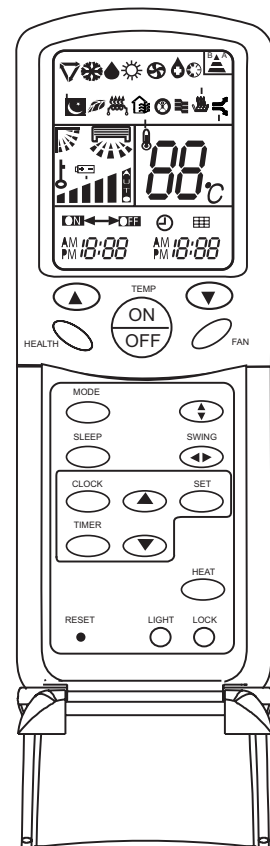

1.5 Address set controller ASC-02

1. Initial connection of power supply

Three seconds after the remote controller is connected to power supply, default symbol "1" of the unit model will be displayed on the LCD and the new icon "↗" shall be transmitted.

2. Operation of remote controller

- The "select" button: The icon "↖" and "↗" is displayed when the button is pressed and please choose "↗".
 - The "Read" button: Pressing of this button will result in simultaneous display of dehumidifying and transmission icons (black water drop and pyramid as shown in the figure)
 - The "Lock" button: This button can be pressed after new code transmission is set. When the button is pressed, the icon "Off" appears on the LCD, then except the Reading button, all the buttons will be shielded with the receiver code locked. If the button is pressed again, icon "Off" disappears and the lock-on function is inactivated for all the other buttons.
 - Machine number button (No.1 to No.6 unit): If the button is pressed, a machine serial button is displayed with a flashing frequency of 1Hz.
 - Set machine number 7,8: press button 6, and within 2 seconds press button 1, then loose them simultaneously, 7 will display in the screen, which stands for selecting unit 7. And then press button "set", you can set unit 7. Then press "READ" to confirm if the unit number is right. With the same method, set unit No.8.
 - Machine number "set" button: This button can be set when machine number flashes on the LCD. Machine number flashing will be set and transmitted if the button is pressed, the machine number stops flashing and a transmission icon (the black pyramid shown in the figure) will appear on the LCD.
 - The "Reset" button: Inset a pointed tool (∅ 2mm) into the hole of the Reset button. Every press of the tool will reset the existing setting, and three seconds later, initial operation mode will appear on the LCD.
- ### 3. Test of remote controller (ie. No. 3 unit)
- Press Unit 3 button, the number 3 flashes with a frequency of 1Hz.
 - Press the machine number "set" button, the selected unit number will be set and transmitted to the receiver of the unit.
 - Press the "Read" button and the selected unit starts read the set machine number. If machine number of selected indoor unit is correctly displayed, (Flash number of the indoor unit power indicator implies machine number) setting of machine number is successful or vice versa.
 - When setting is completed, press the "Lock" button, (for new number remote controller only) and the icon Lock-on appears on the LCD, then the machine number of the indoor unit is locked. Usually machine numbers do not need to be locked.
- ### 4. A slight sound may be produced by the indoor unit when the signal from the remote controller is received.

Note: Do not set machine numbers for more than one indoor unit before a lapse of 20 seconds after completion of setting of machine number of an indoor unit.

Note:

1. Do not set machine numbers for more than one indoor unit before a lapse of 20 seconds after completion of setting of machine number of an indoor unit.
2. Address set controller is necessary for H MRV AB (Cassette type), AC (Convertible type), AF (Console type), AS (Wall mounted type) installation.

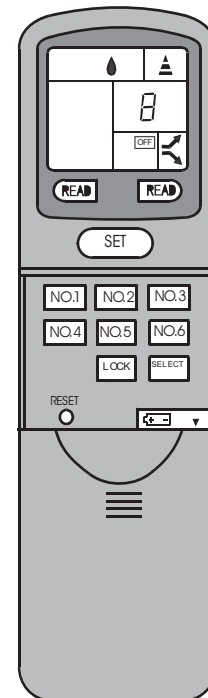

1.6 Wired controller YR-E06

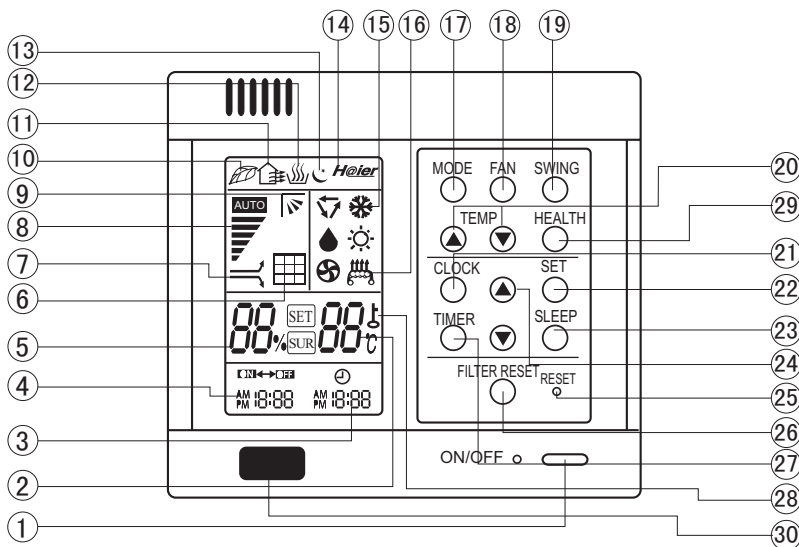

1.ON/OFF button

Used to turn on/off unit

2.Temperature display

3.Clock display

4.Timer ON/OFF display

5.Humidity display

6.Air filter cleaning display

When there is too much dust collected on the air inlet, the wire controller will show this display to remind the user to clean the air inlet. After cleaning and installation, just press the air filter reset button.

7.Super/Soft operation display

8.Fan speed display



9.Auto Swing display

10.Health state display

11.Fresh air state display

12.Humidifying state display

13.Sleep state display

14.Network control display

15.Working mode display

Working mode	Auto operation	Cooling operation	Dehumidifying operation	Heating operation	Fan operation
Wire controller					

16.Electric heating display

17.Operation mode button

Used to set working mode: Auto, Cooling, Dehumidifying, Heating, Fan

18.Fan speed button

Used to set fan speed: Low Fan, Med Fan, High Fan, Auto

19.Swing button

Used to set Auto Swing or Fixed air sending direction

20.Temperature Setting button

Used to set temperature, temperature range: 16 C~30 C

21.Clock button

Used to calibrate the time of timer and clock

22.Setting button

Used to confirm the time of timer and clock

23.Sleep button

Used to set Sleep state

24.Time Adjusting button

Used to adjust the time of timer and clock

25.Reset button

When the wire controller appears abnormal condition, use a sharp-pointed article to press this button to make the wire controller resume normal

26.Air Filter Reset button

After cleaning the air inlet, press this button, the unit can start to operate

27.Timer button

Used to set the mode of timer

28.Lock state display

29.Health

Used to control the generating oxygen function and negative ion-function

30.Remote control window

Used to receive the remote control signal

Note: 1.This model does not have the following related display and function (5)(6)(7)(9)(11)(12)(14)(16)(26)
 2.The outdoor unit no oxygen-bar function or no negative ion unit no (10)(29) health function and health display.

Calibration of clock

When turning on the unit for the first time, the clock should be calibrated. The method of calibration is:

- 1.Press "Clock" button, the Clock display " AM" " PM" will flash.
- 2.Press ▲ or ▼ to adjust time. For each press, the time will increase or decrease 1 minute. If depressing the button, the time will increase or decrease rapidly.
- 3.After confirming the time, press " Set" button, " AM" or " PM" will stop flashing, the clock will begin to work.

Recommendations

- Use COOL in summer.
- Use HEAT in winter.
- Use DRY in spring, autumn and in damp climate.

(1) Unit

Press ON/OFF button, unit starts.
Previous operation status appears on display (Not Timer setting). Power indicator lights up.

(2) Select operation

Press MODE button. For each press, operation mode changes as follows:



Unit will run in operation mode displayed on LCD. Stop display at your desired mode.

(3) Select temp.

Press TEMP button

- ▲ Every time the button is pressed, temp. setting increases $^{\circ}1\text{ C}$.
If button is kept depressed, temp. setting will increase quickly.
- ▼ Every time the button is pressed, temp. setting decreases $^{\circ}1\text{ C}$.
If button is kept depressed, temp. setting will decrease quickly.
Unit will start running to reach the temp. setting on LCD.

(4) Fan speed

Press FAN button. For each press, fan speed changes as follows:

Wire controller



Remote controller

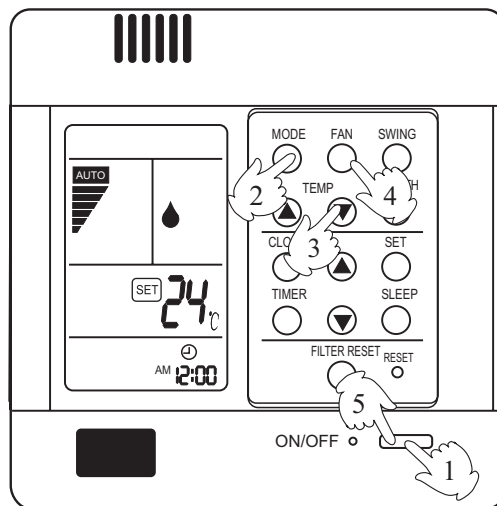

Unit runs at the speed displayed on LCD. In HEAT mode, warm air will blow out after a short period of time due to cold-draft prevention function.

In DRY mode, when room temp. becomes 2 C higher than temp. setting, unit will run intermittently at LOW speed regardless of FAN setting.

(5) Unit stop

Press ON/OFF button.
Only time and room temp remains on LCD.
All indicators go out.
Vertical flap closes automatically.

Hint

Wire controller can memorize each operation status.
When starting it next time, just press ON/OFF button and unit will run in previous status.

- Auto running: During the Auto running mode, air conditioning running and can auto-select the cooling, heating, fan mode according to the room temperature.
- Fan running: The AC only have air supply running no cooling and heating running at the condition, AC can't have auto air supply running, and can't display the setting temperature value on the LCD.
- During the heating running, after start the AC, in order to prevent cooled air, AC can stop for a while before send heat air.
- During the dehumidification running, when the room temp. setting temp. , not setting condition according to the air speed.

Set Clock correctly before starting Timer operation.

You can let unit start or stop automatically at following time: Before you wake up in the morning, or get back from outside or after you fall asleep at night.

TIMER

(1)After unit start, select your desired operation mode.

Operation mode will be displayed on LCD. Power indicator lights up.

(2)TIMER mode selection

Press TIMER button to change TIMER mode. Every time the button is pressed, display changes as follows:



Select your desired TIMER mode (ON or OFF)

(3)Timer setting

Press TIME ▲/▼ button.

- ▲ Every time the button is pressed, time increases 10min. If button is kept depressed, time will change quickly.
 - ▼ Every time the button is pressed, time decreases 10min. If button is kept depressed, time will change quickly.
- Time will be shown on LCD. It can be adjusted within 24hours.

(4)Confirming your setting

After setting correct time, press SET button to confirm "ON" or "OFF" stops flashing. Time displayed: Unit starts or stops at x hour x min (ON or OFF). Timer mode indicator lights up.

To cancel TIMER

Just press TIMER button several times until TIMER mode disappears.

- According to the setting timing open, close sequence, can realize first open then close the unit or first close then open the unit.

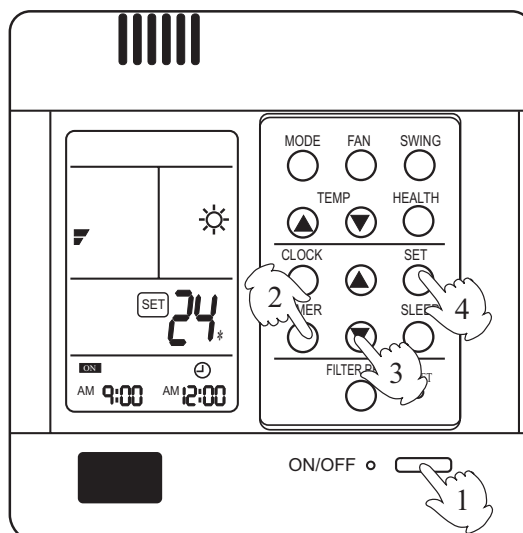

Hints:•Wire controller possesses memory function, when use TIMER mode next time, just press SET button after mode selecting if timer setting is the same as previous one.

- Wire remote controller or remote controller can memorize each working condition. Next time open the unit, only need to press the ON/OFF key, the AC can work according to last time working condition.(Timing, Sleeping and Swing mode not included.)
- From Timing close to timing open, can setting sleep mode.
- Please close health function first before setting Timer, then you can do the TIMER ON operation. Please do not use the health function when in TIMER ON state.

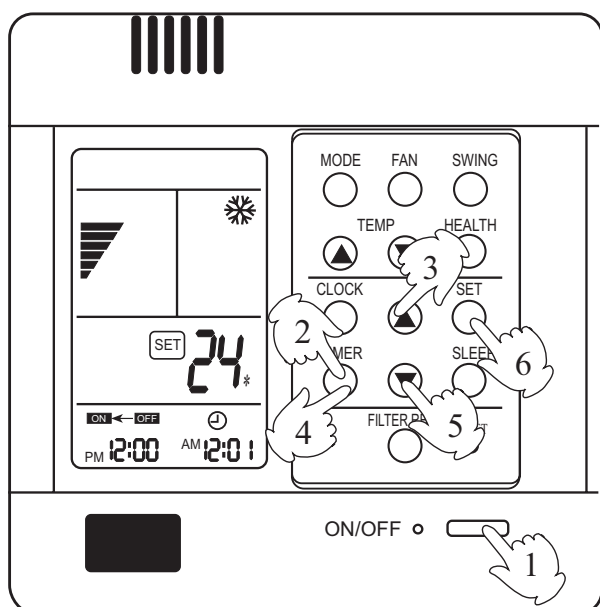

TIMER ON-OFF

(1) After unit start, select your desired operation mode

Operation mode will be displayed on LCD. Power indicator lights up.

(2) Press TIMER button to change TIMER mode

Every time the button is pressed, display changes as follows:



Select ^{ON}
_{OFF} .

(3) Time setting for TIMER ON

Press TIME button.

- ▲ Every time the button is pressed, time increases 10min. If button is kept depressed, time will change quickly.
- ▼ Every time the button is pressed, time decreases 10min. If button is kept depressed, time will change quickly. Time will be shown on LCD. It can be adjusted within 24 hours.

AM refers to morning and PM to afternoon.

(4) Time confirming for TIMER

After time setting, press TIMER button to confirm. "ON" stops blinking, While "OFF" starts blinking.

Time displayed: Unit starts at X hour X min.

(5) Time setting for TIMER OFF

Follow the same procedures in "Time setting for TIMER ON".

(6) Time confirming for TIMER OFF

After time setting, press SET button to confirm. "OFF" stops flashing.

Time displayed: Unit stops at X hour X min.

To cancel TIMER mode

- Just press TIMER button several times until TIMER mode disappears.
- According to the Time setting sequence of TIMER ON or TIMER OFF, either Start-Stop or Stop-Start can be achieved.

Note: Before using this function, must adjust the clock, or the sleep function will be disordered.

Comfortable Sleep

At night, before going to bed you can press down the SLEEP button on the controller and the air-conditioner will run by the comfortable sleeping mode to make you sleep more comfortable.

Press SLEEP button once to make the air conditioner have the pre-set sleep time (first power-on is "1h"), the sleep symbol will appear. Press time button ▲/▼, you can choose the time in 1~8 hours. Each press of ▲/▼, the time increases/reduces 1hour and "xh" appear in the humidity setting area, "OFF" appears in "TIMER OFF" display area and timer-off time; press SLEEP button again to cancel sleep function, the sleep symbol disappears.

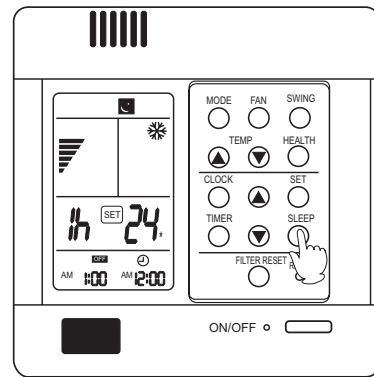

In cooling, dehumidifying mode

One hour after sleeping operation start, the temp. is 1°C higher than the setting one. After another hour the temp. rises 1°C and then run continuously for another 6hrs' and then close. The actual temp. is higher than the setting one which is to prevent from being too cool to your sleep.

In heating mode

One hour after start up, the temp. decrease 2°C lower than the setting one. After another hour decrease by more 2°C.

The temperature will automatically rise by 1°C after another 3hrs' operation, and then automatically close after 3hrs' continuous operation. The actual temperature is lower than the setting one which is to prevent from being too hot to your sleep.

Note: In AUTO mode, unit will run in SLEEP function according to the operation mode.

After setting SLEEP function, it is forbidden to calibrate clock.

If the set sleep-time does not reach 8 hours, the unit will stop operation automatically after set time is complete.

Set "TIMER-OFF" function first, then set SLEEP, and the sleep-set is performance; set TIMER-ON function first, the sleep function can only be set before TIMER-ON; if set the SLEEP function first, the TIMER function can not be set.

- After setting sleep function, not allowed to adjust the clock. Can't use the remote controller operate the AC. If so, please cancel the sleep function first.
- After setting sleep function, can't set the timing function.

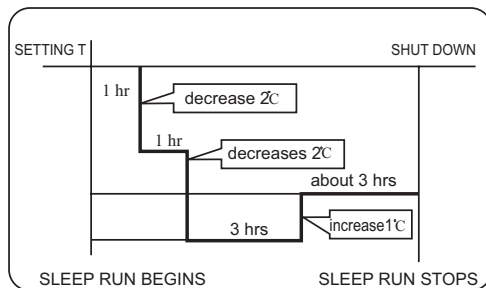

Heat mode

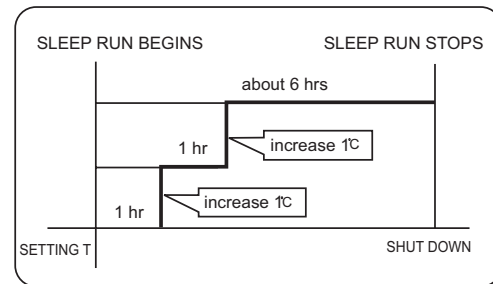

Cooling mode

Auto restart function (to be applied for a necessary situation) :

After the auto-restart function is set, if power failure suddenly occurs while the air conditioner is working, it will resume the previous working state when the power is supplied again.

Setting Method: When the remote controller is on (excluding timer mode and fan mode), press the "SLEEP" button on the remote controller 10 times within 5 seconds, and after the buzzer rings 4 times, the air conditioner will enter the state of auto-restart function.

Cancel Method: Press the "Sleeping" button on the remote controller 10 times within 5 seconds, and after the buzzer rings 2 times, the power failure compensation mode will be cancelled.

Notes: When a power failure suddenly occurs during the air conditioner is working after the power failure compensation is set, if the air conditioner will not be used for a long time, please cut off the power supply to prevent its operation from being resumed after the power is supplied again, or press the "Switch On/Off" button after the power comes again. If the controller no sleep key, use the "swing" key instead the "sleeping" on setting the auto restart function.

Concerning MRV Auto Restart function for H-MRV models

Haier Auto Restart function when the unit power drops down suddenly, the unit microprocessor will store the previous working condition and when the power is on again, the unit will run as this memory.

Auto Restart function is designed basically on the MRV whole system, but it is suitable for each indoor unit individually.

If some of indoor units power cut down, but the outdoor unit and the other indoor units still work, maybe problems will happen such as freezing at cooling mode and overload protection at heating mode on those indoor units without power.

Reason

When one or some indoor units power drops down and the other indoor units are still work, the indoor units without the power, will keep the previous working condition before the power is off. And expansion valve keeps open at a kind of opening rate condition as the previous requirement, so there is refrigerant flowing in the exchanger, but the indoor fan stops working. If the units work at cooling mode, the indoor units without the power will maybe make freezing. If the unit works at heating mode, maybe the outdoor unit compressor will stop because of the pressure or temperature protection. This is our design basically on Auto Restart function currently.

Haier, Herewith, solemnly informs our customers, installers, distributors, etc. **when making installation, please make sure when the power is shut down whether artificially or accidentally, the whole system including outdoor unit and all the indoor units must be off. If you do not make the installation as our indication, Haier will not be responsible for any problem resulting from this.**

User Caution

About the remote control operation, above only take wired remote controller and remote controller as a example about the remote controller and remote receiver use method, it is the same remote controller, please use refer to above method.

No sleep function when use remote and remote receiver.

About health function

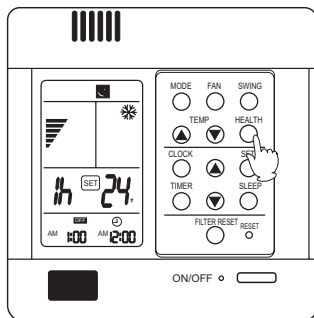

- On the "Health" mode, if you want to setting timing open mode, should close the health first: On the timing open mode, please don't use health function.

1.How to use the health function (only for units with this function)
After set the right function mode, press health button, remote controller or wire controller displays "🌿", oxygen pump or negative ion generator starts up to apply oxygen or negative ion to indoor unit. Press the button again, the sign "🌿" disappeared and negative ion generator stops working. After all health function of the indoor unit being fully canceled, oxygen pump stopped.

CAUTION:

When the temperature of the outdoor unit is lower than 4°C , oxygen pump is automatically stopped, if press health button just then, oxygen pump could not start up. But if the air conditioner has the negative ion function simultaneous, when press the health button, negative ion function could still be operated. When the temperature of the outdoor unit is higher than 6°C , oxygen pump could automatically resume to oxygen-make function.

For H-MRV wired type indoor unit, the wired controller can be matched with the remote controller YR-H71 to realize the remote control function.

Left picture is a wired remote controller, which can be used on Series wired control units ,The remote controller can be purchased extrally.

Wired remote Controller using method:

- 1.Use one wired remote controller. See fig (1)
- 2.Also can buy a remote controller extrally, realize wired remote control + remote control dual control modes.
- 3.When the remote controller can be used on series wired remote controller units ,than please press the botton "CODE"to choose the program of code "A"

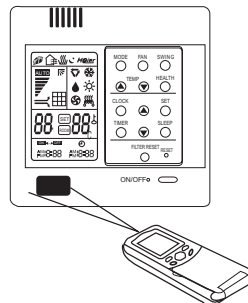
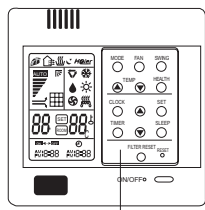
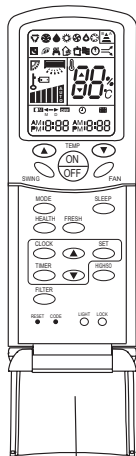

Remote controlller Wire remote controlller
Remote controlller is an accessory, to be ordered extrally

1. Remove upper cover of wire controller

Remove upper part of wire controller by press.

PCB is mounted on lower part of wire controller, be careful not to damage it.

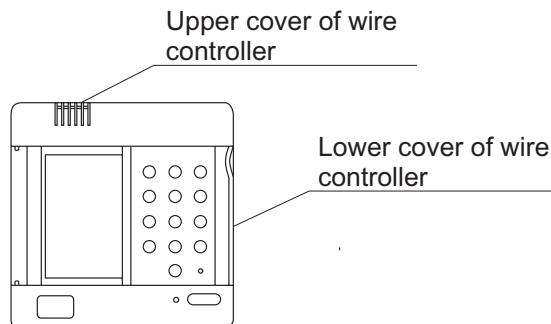

2. Install the wired remote controller

Please drill two holes on the wall according to the back cover screw hole position of the wire remote controller, then strike the wood block to the holes respectively, then align the 2 screw hole of the wire controller back cover to the wood block, fasten the wire remote controller to the wall use wood screws.

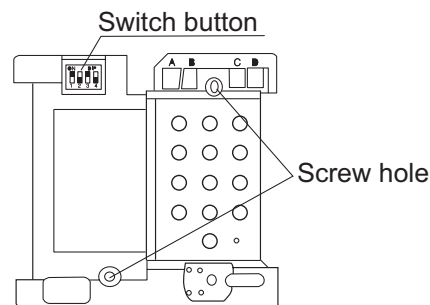

3. Switch setting

The switches setting as follows: 1.ON 2.OFF 3.ON 4.OFF

Note

Try as far as possible a flat surface for installation. Don't use excessive force when tightening screws, or lower part might get deformed.

4. Connecting method as the following chart

No	Symbol	colour	contents
1	A	White or Green	12V
2	B	Red	Gnd
3	C	Yellow	COM
4	D	—	—

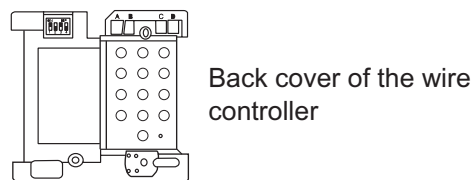

- Use shielded wires for telecommunication between wire controller and indoor unit; indoor unit and outdoor unit. Ground the shield on one side.
- Otherwise misoperation because of noise may occur.
- Signal wire is self-provided by user.

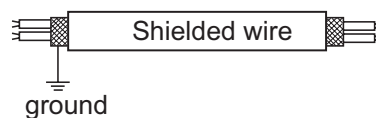

5. Functions of dip switch

No	ON	OFF
1	H MRV or Fixed frequency types	Single split inverter
2	Has [free elevating inlet grill] function	No [free elevating inlet grill] function
3	Has [swing] function	No [swing] function
4	Use the ambient sensor in indoor unit	Use the ambient sensor in wired controller

6. Replace the upper cover of wire controller

Be careful not to hold down the wiring.

Hint 1. Power supply switch and signal wire should be prepared by the user.
2. Don't touch PCB with hand.

The first site of dip switch in YR-E06 is used to distinguish different types, ON:H MRV or Fixed frequency types, OFF:Single split inverter. Their diagnostic codes are different.

Error Description	SW1-1	
	ON	OFF
Normal state	--	--
Indoor ambient temp. sensor error	E1	F1
Indoor pipe temp. sensor error	E2	F2
Indoor pipe is over-heat in heating mode	F4	F4
Indoor pipe is in anti-freezing function in cooling	F5	F5
Communication error between indoor and outdoor units	E9	E3
Communication error between indoor and wired controller	E8	F7
Outdoor power model error	E0	E1
Outdoor current is too low	F2	E2
Compressor is over-heat	F6	E4
CT current is over high/one phase of power line is lost	E5	E5
Outdoor ambient temp. sensor error	E3	E6
Outdoor pipe temp. sensor 1 error	E4	E7
The voltage is over-high or over-low	E7	E10
Outdoor high or low pressure error	E6	E13
Outdoor pipe temp. sensor 2 error	E15	E15
The indoor pipe sensor temp. is too high	E12	E12
Outdoor pipe temp. sensor 3 error	E14	E14
Outdoor suction temp. sensor error	E13	E11
Compressor temp. sensor error	F7	E9
Indoor mid-evaporator temp. sensor error	F3	F3
Indoor PCB error	F8	E8
Water outlet system problem	E0	F6
Power lines is in wrong connection turn or one phase is lost	E10	F0
Humidity sensor error	E11	F8

1.7 Wired controller YR-E12

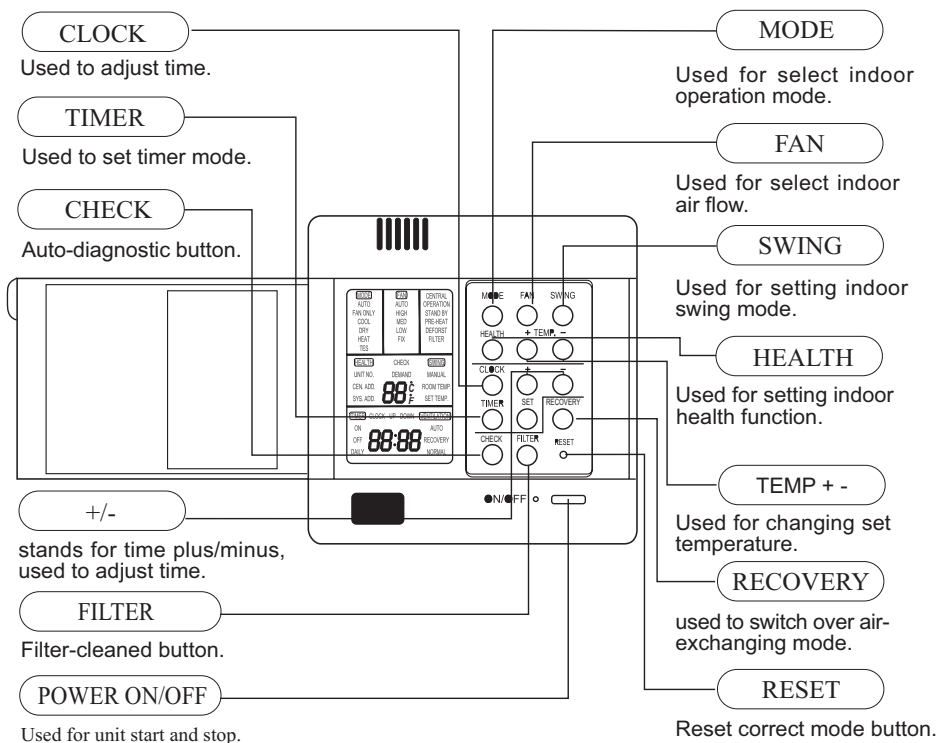

[MODE]

[AUTO]:Auto operation mode.

[FAN ONLY]:air-throwing mode.

[COOL]:Cooling operation mode.

[DRY]:Dehumidification mode.

[HEAT]:Heating operation mode.

[TES]:In heating mode, auxiliary electric heater is running. Only when the unit with auxiliary electric heater is in auxiliary electric heating mode, it will display.

[FAN]

[AUTO]:Auto fan running.

[HIGH]:High fan speed.

[MED]:Medium fan speed.

[LOW]:Low fan speed.

[FIX]: Fixed fan speed, it will display only when fixed fan speed is requested to main indoor unit.

[CENTRAL]:Central control mode.

[OPERATION]:Running mode.

[STAND BY]: Waiting mode.

[PRE-HEAT]: Pre-heating mode.

[DEFROST]: Defrosting mode.

[FILTER]: Request of filter to be cleaned.

[HEALTH]:Health function.

[CEN.ADD]:Central control address, the address number will display on "88".

[SYS.ADD.]:System address, the address number will display on "88".

[CHECK]:Auto-diagnostic, trouble shooting.

[DEMAND]:Compulsory operation function, when it works, [CENTRAL] will flash.

[SWING][MANUAL]:Swing mode.

[ROOM TEMP.]:Indoor ambient temperature.

[SET TEMP.]:Set admired temperature.

[TIMER]

[ON]:Timer function is on.

[OFF] :Timer function is off.

[ON][OFF] :Timer function ON-OFF.

[ON][OFF][DAILY]:Timer ON-OFF will switch over in turn daily

[CLOCK]:Clock display, the displaying time is the current time of the clock.

[UP],[DOWN]:Indicator of filter elevating.

[VENTILATION]

[AUTO]:Auto ventilation mode.

[RECOVERY]:Fully heat exchanging ventilation mode.

[NORMAL]:Normal ventilation mode.

FAN ONLY OPERATION(See picture 1):

- 1) Start up operation: press the button of ON/OFF, the system will start up, and will display on LCD.
- 2) Select MODE: press the MODE button, then you will see in the display section [MODE] switch over in below sequence:[FAN ONLY] → [COOL] → [DRY] → [HEAT] → [AUTO] → [FAN ONLY]. Select [FAN ONLY].
- 3) Select fan speed: press FAN button, then you see in the display section [FAN] switch over in below sequence: [HIGH] → [MED] [LOW] → [HIGH]. Select proper fan speed.
- 4) Power off: press ON/OFF button, indoor unit will be powered off, there are only time and the ambient temperature in the screen.

AUTO operation, COOLING, HEATING and DEHUMIDIFICATION operation (See Picture 2):

- 1) Start up operation: press the button of ON/OFF, the system will start up, and will display on LCD.
- 2) Select MODE: press the MODE button, then you will see in the display section [MODE] switch over in below sequence:[FAN ONLY] → [COOL] → [DRY] → [HEAT] → [AUTO] → [FAN ONLY]. Select [COOL].
- 3) Change set temperature: press TEMP + or - every time, [SET] will display, and set temperature will increase/reduce 1 C (F).
- 4) Select fan speed: press FAN button, then you see in the display section [FAN] switch over in below sequence: [AUTO] → [HIGH] [MED] → [LOW] → [AUTO]. Select proper fan speed.
- 5) Select [SWING]: press [SWING] button, [SWING] will display, swing function is valid, press again, [SWING] will disappear, swing function is invalid.
- 6) Set [HEALTH]: used to set the indoor health function. Press it once, [HEALTH] will display in the display section, then indoor health function is valid. Press it again, [HEALTH] will disappear, then the health function is invalid.
This function is valid only for the unit with health function.
- 7) Power off: press ON/OFF button, indoor unit is powered off. There are only time and the ambient temperature in the screen.

Set TIMER operation:

Adjust clock: when powered on, for the first time to set timer function, the clock will be adjusted.

Press "CLOCK" button, and set the current clock. Now, "CLOCK" will flash at the frequency of 2Hz . Press the clock +/- button; the current clock can be adjusted. Until the proper time comes, press [SET].

TIMER ON operation:

Press TIMER button, and keep pressing it, in the display section [TIMER] will switch over in below sequence: [ON] → [OFF] → [ON][OFF] → [ON][OFF][DAILY] → []. Select [TIMER] [ON], then [TIMER] [ON] flashes, press the clock +/- button to adjust the time of TIMER ON, press [SET] button.

Note:

1. If the two times are same, the timer state which is set later will flash, in this case, timer can not be set.
2. When entering TIMER setting state, if you do not input any button in continuous 10 seconds, the unit will quit from the TIMER mode.

Cancel TIMER operation:

In the timer operation state, press [TIMER] button, the unit will quit from the current timer operation state, and the set data will be memorized, then enter the next timer mode. When [TIMER] dose not display, the timer will be cancelled.

[FILTER] function

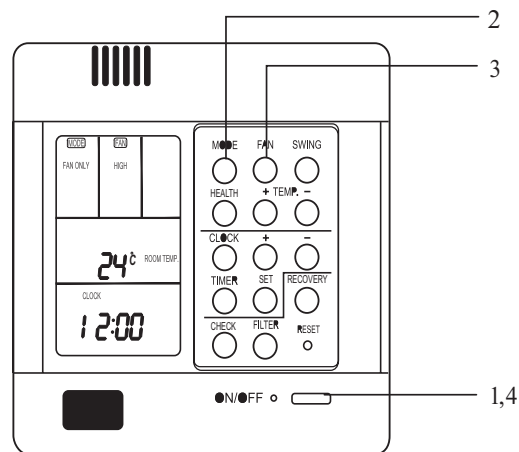

Picture 1

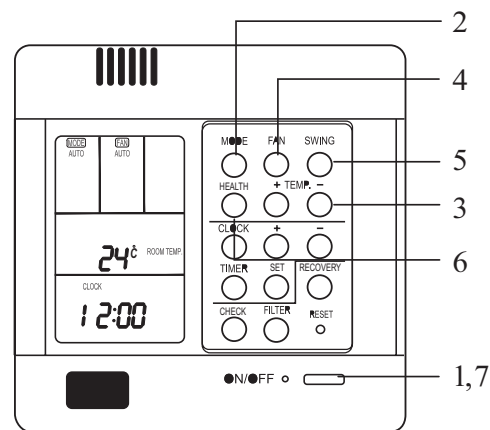

Picture 2

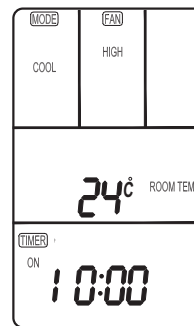

FILTER ELEVATING function: (only for the unit with elevating function)

When the filter needs to be cleaned, the panel can be lowered to the admired height by the [FILTER][UP][DOWN] function. Method is below: In power off state, press [HEALTH] for 15 seconds to enter filter elevating set state. In this state, the sign [FILTER] will flash and [UP] [DOWN] will display simultaneously, Press TEMP [+], in timer section [UP] will display, while press TEMP [-], in timer section [DOWN] will display. When it arrives the appropriate position, press [UP], [UP][DOWN] will display simultaneously, filter will stop going down. Press [UP] again, filter will go up. Press [FILTER] button to quit the mode.

Trial running operation function:

By this function, all the indoor units can be made in nominal mode. Set the operation mode in cooling and then shut off the unit. In the stop state, press [ON/OFF] button for 5 seconds to enter cooling trial operation state. If it is in heating mode before shut off the unit, then press [ON/OFF] button for 5 minutes, it will enter heating trial operation state. In cooling, there will be "LL" in the position where the set temperature displays. In heating, there

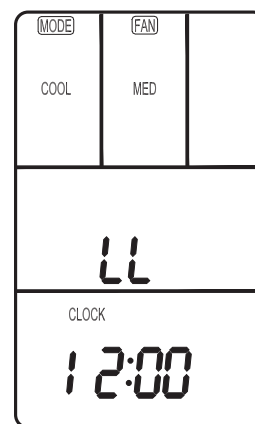

Picture 3

VENTILATION mode (only for the unit with fresh air function or heat recovery function)

Press [RECOVERY] button, then the unit will switch over the ventilation mode:

[] [VENTILATION][AUTO] [VENTILATION][RECOVERY] [VENTILATION][NORMAL] [], please select appropriate ventilation mode.

Query indoor malfunction history:

In the state of power on or power off, press [CHECK] button, enter the malfunction-querying mode of all indoor units in the group. Then [CHECK] and [UNIT NO.] will display, and the actual indoor numbers will be displayed in some sequence (unit number is in decimals). At the same time, in the time region, there will be the current malfunction and the latest time malfunction, the displaying format is [XX:YY], in which XX stands for the current malfunction, if normal, it will display "---"; YY stands for the latest time malfunction. The failure code of every unit will display for 3 seconds. After the failure codes of all indoor units in the whole group are displayed, the mode will quit automatically.

Clear abnormal state and malfunction history:

In normal state, press [CHECK] button for 5 seconds to clear abnormal states, at the same time, wired controller

Y	ZZZ	Type
A	Indoor capacity (W)	Nominal cooling capacity/10, decimal
B	Request of indoor capacity(Hz)	Actual value, decimal
C	Temperature of indoor ambient temp. sensor TA	Actual value, decimal
d	Temperature of indoor gas pipe sensor TC1	Actual value, decimal
E	Temperature of indoor liquid pipe sensor TC2	Actual value, decimal
F	Open degree of indoor PMV	Actual value, decimal
g	Preset	---
H	Outdoor total capacity	Actual value, decimal

In check mode, press [CHECK] to quit the check mode, and go into normal running mode.

How to change the function switches?

No.	Type	State of switch	Function description
J01	Changeover of Wired controller and central controller	Connected	Central controller
		Cut off	Wired controller
J02	Changeover of type of wired controller	Connected	Set as simple controller
		Cut off	Set as standard controller
J06	Selection of room temp. sensor	Connected	Use the sensor in the wired controller
		Cut off	Use the sensor in the indoor unit
J07	Auto restart after power failure	Connected	Common control
		Cut off	Auto restart after power failure
J03	Display of room temperature	Connected	Yes
		Cut off	No
SW01 ①	Changeover of master or slave controller	ON	Set as slave controller
		OFF	Set as master controller
SW01 ②	°C or °F	ON	°F
		OFF	°C
D1	Shorten time function	Connected	Indoor unit in shorten time function
		Cut off	Common control
D2	Compulsorily defrost	Connected	Send compulsorily defrost signal to indoor unit
		Cut off	Common control

Note: 1. The switches in grey can be operated after opening the cover of wired controller.
 2. Switches or jumper wire must be adjusted when the wired controller is powered off. If the wired controller is powered on, the above operations will be invalid.
 3. Shorten time function

In normal operation, D1 is in short circuit, it will enter shorten time mode, and the time will be shortened in the proportion of 60:1. In shorten time mode, LED will flash at the frequency of 0.5 second. Cut off D1, it will quit the shorten time mode and return to the normal operation mode.

4. Compulsorily defrost

In heating mode, D2 is in short circuit, it will enter compulsorily defrost mode; cut off D2, it will quit.

5. Lock function

There is no lock function only in the wired controller. But when it is connected with a central controller, if the central controller is set to "central", the buttons in the wired controller will be invalid, or the buttons will be valid.

Contrastive items	Master wired controller	Slave wired controller
Function	All of functions	Only with below functions: ON/OFF, MODE, FAN SPEED, SET TEMP., SWING

7. Function difference between simple wired controller and the standard one:

Contrastive item	Standard wired controller	Simple wired controller
Function	With all functions	Only can control ON/OFF, MODE, FAN, TEMP., SWING.
Master/Slave selection	Can be either of Master and Slave controller	Only can be Master controller

1. Wiring connections of wired controller:

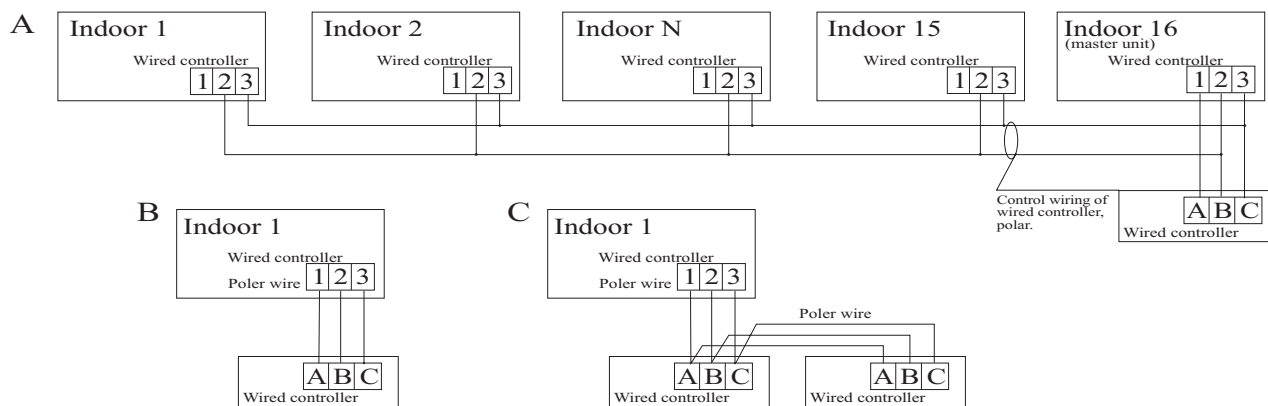

There are three methods to connection wired controller and the indoor units:

A. One wired controller can control max. up to 16 sets of indoor units, and 3 pieces of polar wire must connect the wired controller and the master unit (the indoor unit connected with wired controller directly), the others connect with the master unit through 2 pieces of polar wire.

B. One wired controller controls one indoor unit, and the indoor unit connects with the wired controller through 3 pieces of polar wire.

C. Two wired controllers control one indoor unit. The wired controller connected with indoor unit is called master one, the other is called slave one. Master wired controller and indoor unit; master and slave wired controllers are all connected through 3 pieces of polar wire.

2. Communication wiring:

The wired controller is equipped with special communication wiring in the accessories. 3-core terminal (1-white 2-yellow 3-red) is connected with the terminal A, B, C of wired controller respectively.

The communication wiring is 4 meter long; if the actual length is more than it, please distribute wiring according to below table:

Communication wiring length(m)	Dimensions of wiring
< 100	0.3mm ² x3-core shielded wire
≥100 and <200	0.5mm ² x3-core shielded wire
≥200 and <300	0.75mm ² x3-core shielded wire
≥300 and <400	1.25mm ² x3-core shielded wire
≥400 and <600	2mm ² x3-core shielded wire

*One side of the shielded sheet of communication wire must be earthed.

Note:

The wired controller must be used with cooperation with indoor unit. When wired control type is selected, the function of indoor unit must be adjusted (after power cut off).

The indoor PCB(0010451167) is matched with this wired controller (0010451521) which can be set according to below table:

	Connected	Cut off
J1	Remote control	Wired control
J2	In heating mode, with temperature compensation	Without temperature compensation
J4	Heat pump	Cooly only
J7	Synchronous motor swing	Stepping motor swing
J9	Master unit	Slave unit

When the wired controller controls several indoor units, there is only one Master unit, and other can be set as Slave unit.

3.Setting address method:

The address setting can be realized by setting indoor PCB.

If you use the group control function, there should be a master unit and 15 sets of slave units. For the master unit, the SW5-3 should be at "ON". For the slave units, the SW5-3 should be at "OFF"

Please refer the below table,

Indoor unit address	SW1-4	SW1-3	SW1-2	SW1-1
1	OFF	OFF	OFF	OFF
2	OFF	OFF	OFF	ON
3	OFF	OFF	ON	OFF
4	OFF	OFF	ON	ON
5	OFF	ON	OFF	OFF
6	OFF	ON	OFF	ON
7	OFF	ON	ON	OFF
8	OFF	ON	ON	ON
9	ON	OFF	OFF	OFF
10	ON	OFF	OFF	ON
11	ON	OFF	ON	OFF
12	ON	OFF	ON	ON
13	ON	ON	OFF	OFF
14	ON	ON	OFF	ON
15	ON	ON	ON	OFF
16	ON	ON	ON	ON

4. Diagnostic code display

Failure description	Code on wired controller
Room temp. sensor abnormal	01
Indoor coil temp. sensor abnormal	02
Outdoor temp. sensor abnormal	4A
Outdoor coil temp. sensor abnormal	49
Over-current malfunction	48
High / Low pressure abnormal	53
Communication malfunction between indoor and wired controller	07
Communication malfunction between indoor and outdoor abnormal	06
Drainage system malfunction	08
N/A	0B
Coil gas pipe temp. Sensor abnormal	03
Temperature protection malfunction	0D
Indoor EEPROM abnormal	05

1.8 Central Controller YCZ-A001:

Function description:

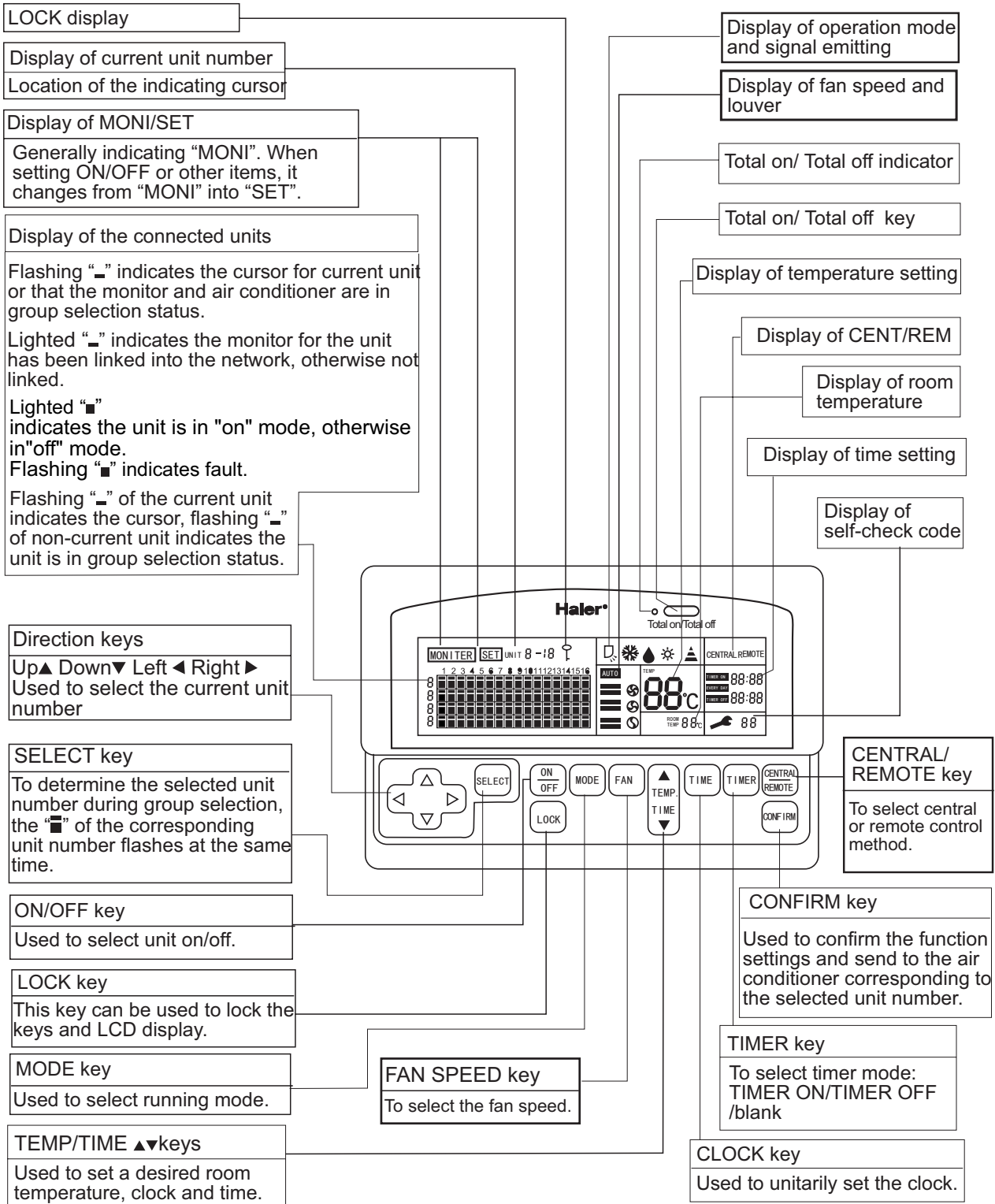

Note: In "MONI" mode, pressing SEL, MODE, FAN SPEED, TEMP TIME keys may change the "MONI" mode into "SET" mode. If "SET" key or other keys hasn't been pressed within 10s, it will automatically return to "MONI" mode.

1. Communication function

Communicate with the indoor PCB in the group control network

To communicate with the indoor PCB through the R S-485 bus (A, B). The central controller sends commands to and receives response from indoor PCB; communication by address enables sending and receiving control information, work information and fault information between indoor PCB and the central controller.

2. LCD display function:

The LCD could display the fundamental status of air conditioning units (are the units existing? On/off? Fault? Are units group selected? Cursor and the current unit no.);

The LCD can display the working status of the air conditioning unit with the current number (mode, fan speed, temperature setting, room temperature, timer, error code, central/remote control status);

The working status of the central controller (monitor/set status, panel locking status, signaling status).

3. Key input function:

The keys for moving the current unit number cursor and for group selection: ▲, ▼, ►, ◀, SELECT;

The keys for setting working status of the air conditioning unit and control conditions: ON/OFF, MODE, FAN SPEED, TEMP, TIME ▲/▼, CLOCK, TIMER, CENT/REM, SET;

The key for locking key function of the central controller: LOCK.

4. Unit number setting function:

To enrich the control functions of Haier commercial air conditioner remote monitoring system, multiple controllers could be set to work together for a combination of multiple functions. For this, the central controller is provided with a two-digit switch for setting controller address.

5. Realizing central control function with the central controller(max.128 indoor units can be connected)

this type is applicable for the free multi indoor units except for console type and wall mounted type.

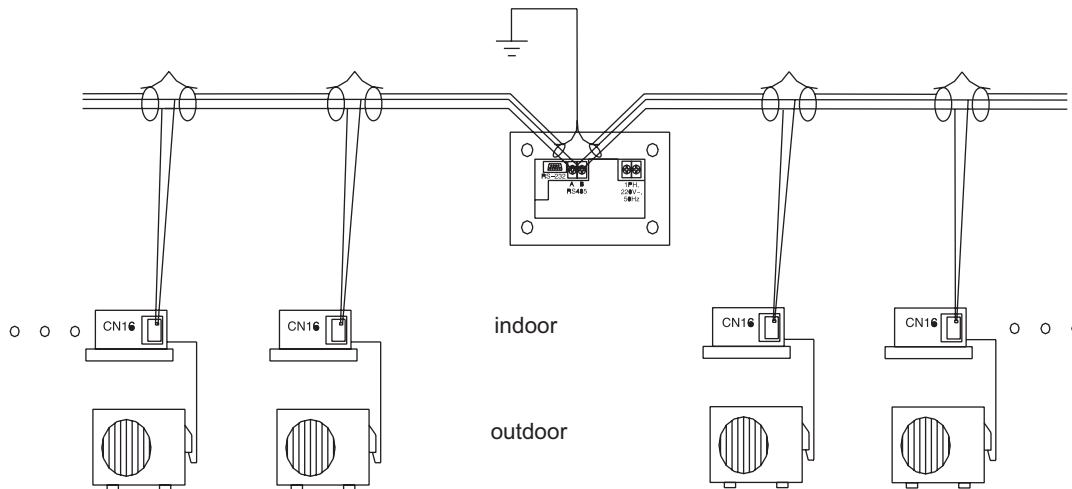

6. Central control system + Group control system(max.128 x16 indoor units can be connected),this type is applicable for the unitary free indoor units except for console type and wall mounted type.

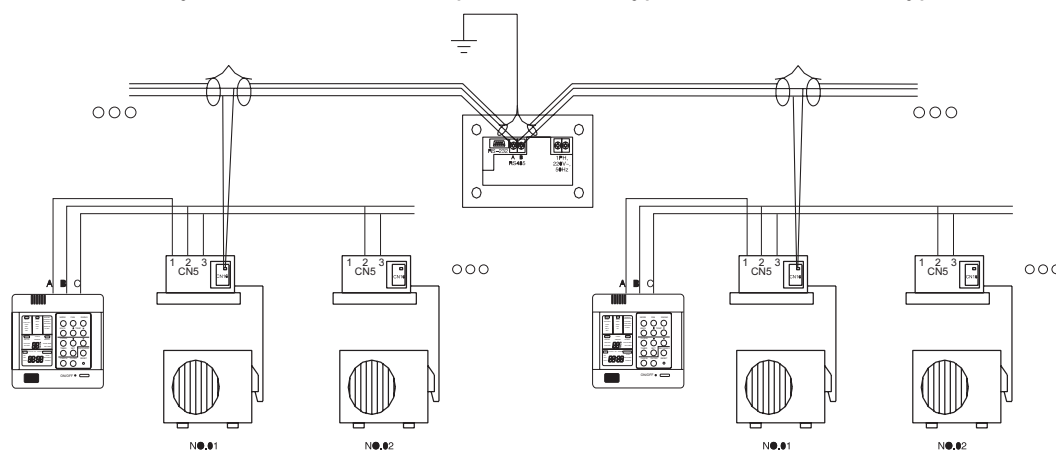

7. Use central controller + weekly timer to realize the group control function + weekly timing function, this type is applicable for the unitary free indoor units except for console type and wall mounted type.

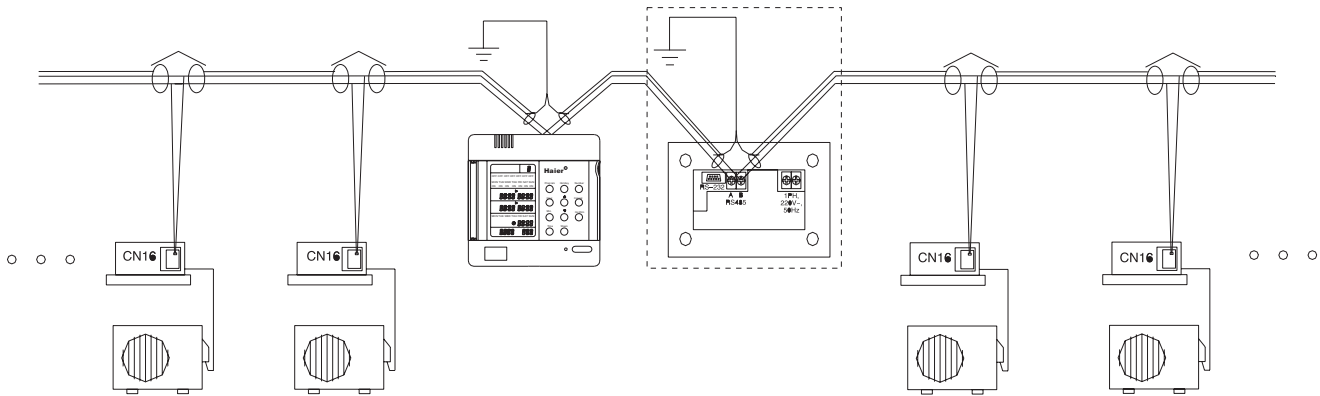

8. Realizing group control function with the central controller, for the unit which needs the detector, such as cosole unit, wall mounted unit.

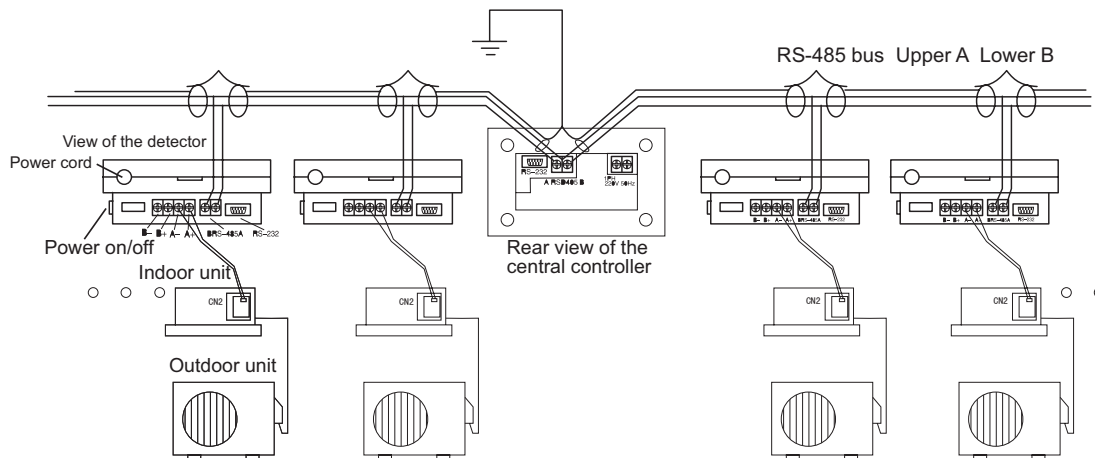

9. Realizing double unit switch-over group control function with the central controller, for the unit which needs the detector, such as cosole unit, wall mounted unit.

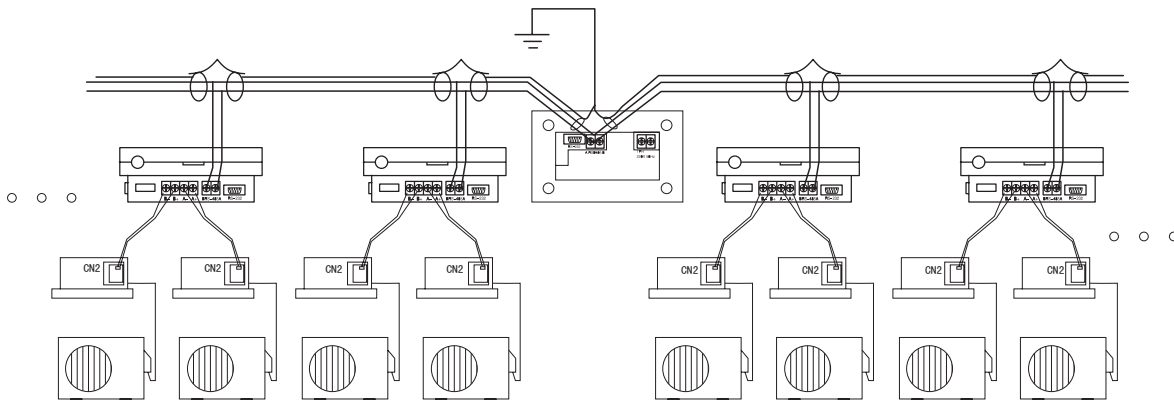

If you use central control type, SW1, SW2 will be used simultaneously.

Wiring request in central control type: port A-B is connected with indoor port CN16 (A-B) through 2-core shield wire. Requirements:

- 1.Port A connects with port CN16 (A) of all indoor units.
- 2.Port B connects with port CN16 (B) of all indoor units.

Address on central controller	Indoor unit address	SW2-3	SW2-2	SW2-1	SW1-4	SW1-3	SW1-2	SW1-1
1	1	ON	OFF	OFF	OFF	OFF	OFF	OFF
2	2	ON	OFF	OFF	OFF	OFF	OFF	ON
3	3	ON	OFF	OFF	OFF	OFF	ON	OFF
4	4	ON	OFF	OFF	OFF	OFF	ON	ON
5	5	ON	OFF	OFF	OFF	ON	OFF	OFF
6	6	ON	OFF	OFF	OFF	ON	OFF	ON
7	7	ON	OFF	OFF	OFF	ON	ON	OFF
8	8	ON	OFF	OFF	OFF	ON	ON	ON
9	9	ON	OFF	OFF	ON	OFF	OFF	OFF
10	10	ON	OFF	OFF	ON	OFF	OFF	ON
11	11	ON	OFF	OFF	ON	OFF	ON	OFF
12	12	ON	OFF	OFF	ON	OFF	ON	ON
13	13	ON	OFF	OFF	ON	ON	OFF	OFF
14	14	ON	OFF	OFF	ON	ON	OFF	ON
15	15	ON	OFF	OFF	ON	ON	ON	OFF
16	16	ON	OFF	OFF	ON	ON	ON	ON
17	-----	ON	OFF	ON	OFF	OFF	OFF	OFF
18	-----	ON	OFF	ON	OFF	OFF	OFF	ON
19	-----	ON	OFF	ON	OFF	OFF	ON	OFF
20	-----	ON	OFF	ON	OFF	OFF	ON	ON
21	-----	ON	OFF	ON	OFF	ON	OFF	OFF
22	-----	ON	OFF	ON	OFF	ON	OFF	ON
.....
128	-----	ON	ON	ON	ON	ON	ON	ON

Installation procedure

1. Wire connecting

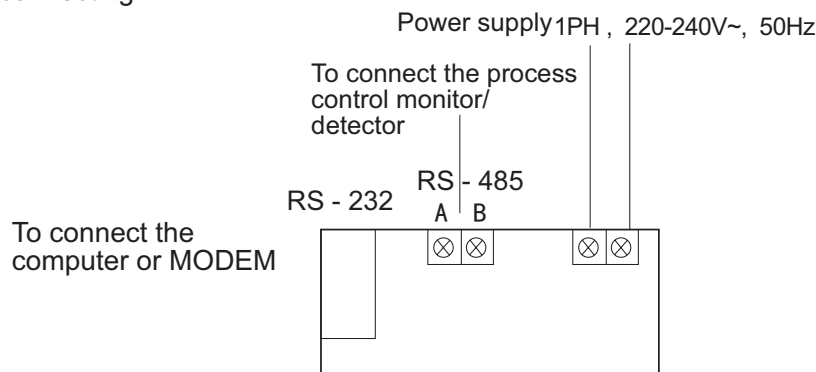

2. Installation method

A wiring box cover must be used.

The central controller shall be installed into the installation box built in the wall fastening with 4 screws (as shown).

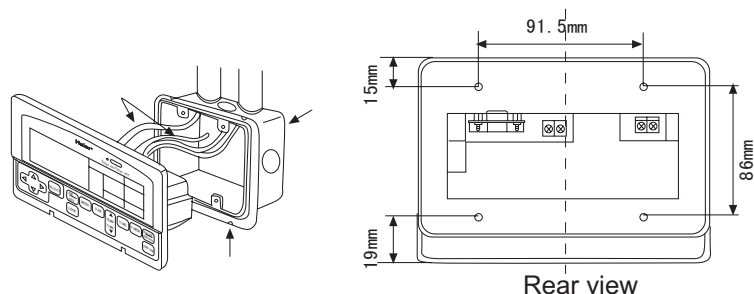

Note: Please confirm the supply voltage of AC220-240V and correct wiring. In application environment with intense electromagnetic interference, the central controller should be shielded, while the connecting wire between the monitor and the central controller should be shielded twin twisted wire.

Exterior dimension

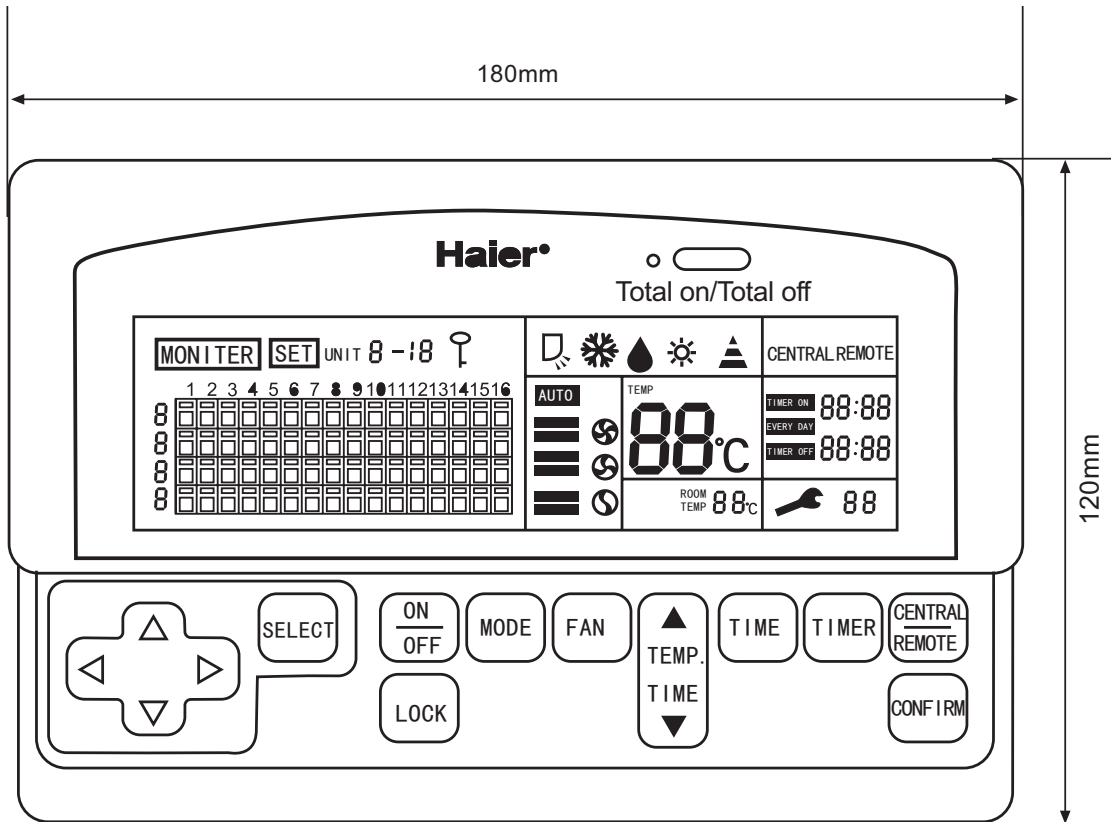

(Fig.1)

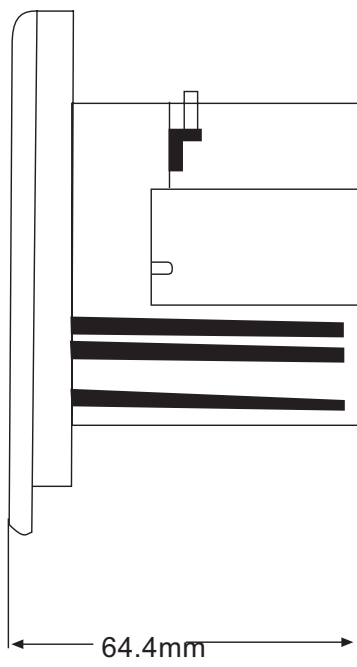

As illustrated:
(Figure 1 is the front view and Figure 2 is the side view) The central controller is 180mm long, 120mm wide and 64.4 mm thick.

(Fig.2)

Failure diagnosis

Upon abnormal operation:

Please read the “User’s Manual” attached with the indoor unit before asking for repairing. You may contact the after-sales technicians after careful checkup.

When faults arise, the symbol “  ” appears along with the error code.

The central controller faults corresponding to error codes are given in the following list (including air conditioner faults and group control network faults):

Code	Meaning
Blank	None (normal operation)
1	Fault with indoor ambient temperature sensor
2	Fault with indoor tube temperature sensor
3	Indoor heating overload protection
4	Indoor cooling icing (overload) protection
5	Indoor & outdoor communication error
6	Communication fault between panel (wire controller) and indoor unit (air conditioner indication, central controller shows 30)
7	Module fault (PFC protection – DC)
8	No load
9	Compressor overheating
10	Abnormal CT current
11	Fault with outdoor ambient temperature sensor
12	Fault with outdoor heat exchanger (tube temperature) sensor
13	Protection of supply overvoltage or undervoltage
14	High voltage protection
15	--- Fault with outdoor evaporator sensor
16	--- Cooling overload
17	EEPROM fault
18	Fault with outdoor return gas sensor
19	Fault with compressor sensor
20	--- Fault with indoor evaporator sensor
21	Drain system failure
22	Power supply 3-phase fault (phase lack or mistake)
23	Humidity sensor malfunction
24	Indoor fan failure (fan overcurrent, fan IPM protection, fan motor element fault)
25	Outdoor fan failure (fan overcurrent, fan IPM protection, fan motor element fault)
26	Low voltage protection
27	--- Electronic expansion valve failure
28	--- Dust remover screen needs cleaning
29	Insufficient refrigerant
30	Abnormal communication between monitor and air conditioner
31	Abnormal communication between monitor and bus

1.9 Central Controller ICR01 0010451974A

1.9.1 Appearance

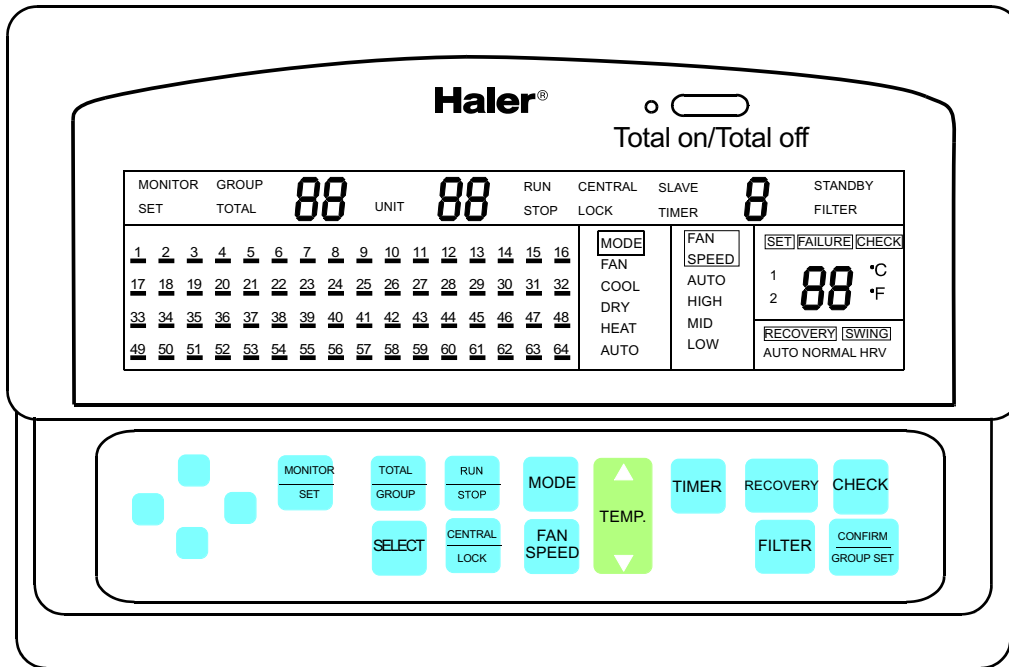

Figure 1

Function description:

ICR01 central controller is developed from YCZ-A001, the operation and dimension is same with YCZ-A001, please refer YCZ-A001 part, ICR01 is used for X Multi, MRVII(R22, R410A) series, YCZ-A001 is used for Unitary Free, Unitary smart and Free Multi seires. But the wiring installation is completely different.

Important! Timer and Recovery buttons are not in use.

1.9.2 LCD icons introduction

LCD of central controller displays indoor state and setting mode of different units.

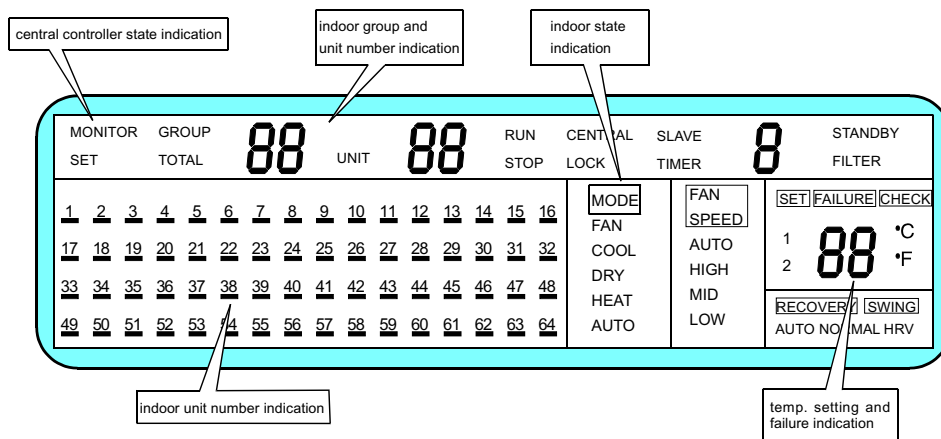
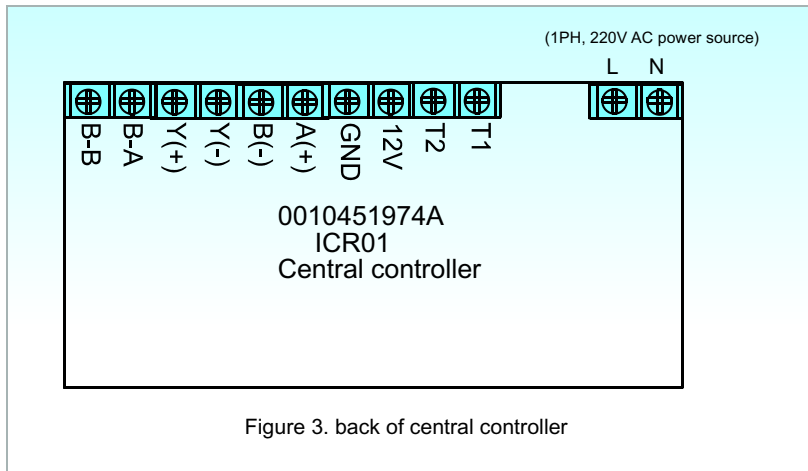
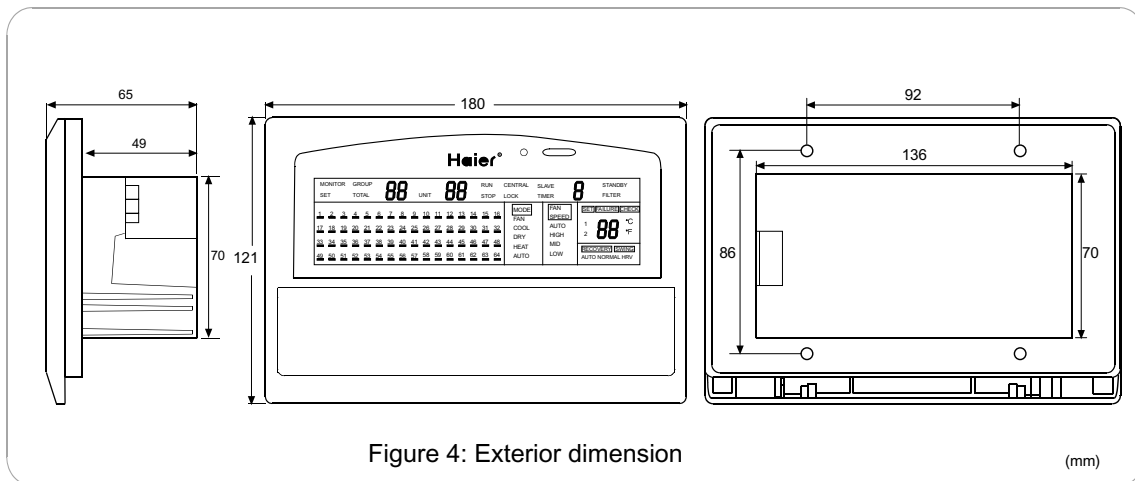

Figure 2: LCD diagram of central controller

1.9.3. Installation drawing



1.9.4. Exterior dimensions for central controller



1.9.5. Communication wire specs

The wire between connecting board to the central controller is the dual-core STP (shielded twisted pair). The detailed specs are as below:

wire length(m)	Specs
<100	0.3mm ² * 2-core STP
≥100 and <200	0.5mm ² * 2-core STP
≥200 and <300	0.75mm ² * 2-core STP
≥300 and <400	1.25mm ² * 2-core STP
≥400 and <600	2mm ² * 2-core STP

※ Shielded layer of communication wire must be earthed on one end.

1.9.6. Dip switch setting of central controller: shown in the below figure (ON:0, OFF: 1)

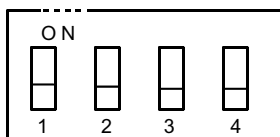

Dip switch setting meaning:

The first bit: central bus line selection, 0: indoor bus line(Install without IGU04); 1: central bus line

The second bit: master/slave central controller selection, 0: master central controller; 1: slave central controller

The third, fourth bit: control range, 00: 1~64, 01: 65~128, 10: 129~192, 11: 193~256. Every central controller only can control 64 units, and every unit can include max. 16 indoors, but the central controller only displays the master indoor state.

position	1	2	3	4
0: ON	indoor bus line	master controller	00: 1~64 01: 65~128	
1: OFF	central bus line	slave controller	10: 129~192 11: 193~256	

For example:

Select central bus line, master central controller, control range is 00, so the dip switch is 1 0 0 0 (default)

Select indoor bus line, master central controller, control range is 00, so the dip switch is 0 0 0 0.

1.9.7. Can set the central control unit as a group, and the max. 64 units of indoor can be set a group.

After setting unit, the indoor in one group can be controlled the same operation (when out of factory, one unit is regarded as one group).

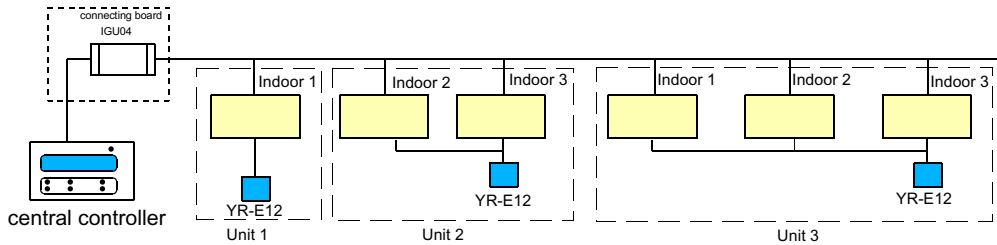

Figure 5 Central unit and group diagram

1.9.8. Control function

1. Features and functions of central controller

Central controller control(ICR01) diagram is as below:

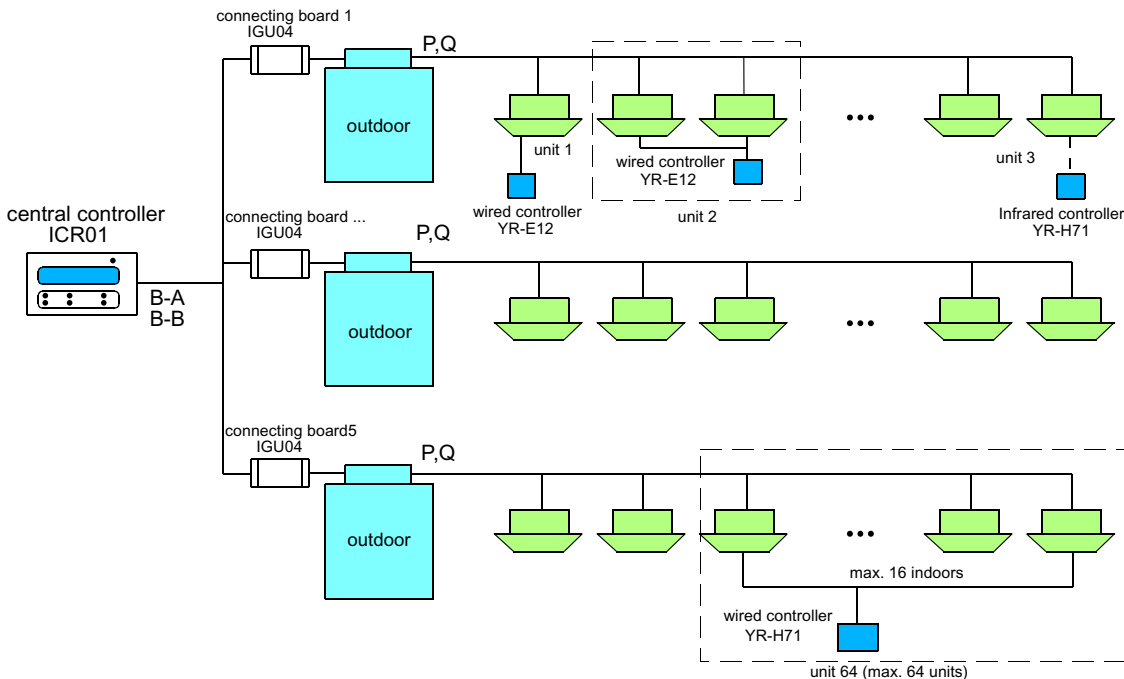

Figure 6 MRV II central control system diagram

1.9.9. Summarization

For installation, connect communication wires from central controller ICR01 port B-A, B-A, to connecting board IGU04. and then connect communication wires from IGU04 P,Q to outdoor or indoor unit communication port P,Q. Notice, the default position of ICR01 dip switch is 1 0 0 0, the address of IGU04 and the indoor address must be set in different number.

When one central controller control one air condition system, also can directly connect wires from ICR01 B-A, B-B port to P, Q port of outdoor or indoor communication port.

Press [check] button, ICR01 will show the diagnostic code, when unit * is in error, and choose the number in ICR01, you will see the diagnostic code, and if not select the error units, the error units' number will be flashing.

Diagnostic code for outdoor master unit

20	Outdoor defrost temp. sensor TE error	The temp. tested from sensor is keeping lower than -60.87°C or higher than 135.4°C for 60 seconds, and system will automatically change to backup running mode.
21	Outdoor ambient temp. Sensor TA error	
22	Outdoor suction temp. sensor TS error	
24	Outdoor oil temp. sensor Toil error	
23	Outdoor discharge temp. Sensor TD error	The temp. tested from sensor is keeping lower than -4.45°C or higher than 337.14°C for 60 seconds, and system will automatically change to backup running mode.
25	Master compressor current is over high	Signal comes from MCU 840
26	Communication error between indoor and outdoor unit	Outdoor didn't find any indoor unit
27	Compressor oil temp. is over-high	Oil temp. is keep higher than 90°C for 5 minutes, when the temp. is lower than 75°C, the alarm will be disappeared automatically.
28	Master unit high pressure sensor error	The signal voltage is higher than 4.9V, or lower than 0.1V for 30 seconds
29	Master unit low pressure sensor error	
30	High pressure switch alarms for over-high pressure	The switch keep open for 1 minute, alarm, if switch keep short-connecting for over 1 minute, the alarm will be gone automatically
31	Low pressure switch alarms for over-high pressure or over-low pressure	
32	Inverter IPM problem	Signal comes from MCU 840
33	Master unit PCB MB89F538 EEPROM error	EEPROM data is lost or is installed in wrong way.
34	Outdoor compressor discharge temp. sensor alarms	Discharge temp. sensor TD1 temperature is higher than 125°C for 10 seconds, when lower than 100°C, resume
35	The protection part in inverter compressor is acted	Check the part in compressor.
37	Master unit high/low pressure sensor is installed in wrong turn	In the first 3 minutes of compressor running, Pd/Ps<1 for over 60 seconds
39	Master unit low pressure sensor alarms	Cooling: Ps< 0.2kgG/cm ² for 30 seconds, alarm Heating: Ps <-0.2kgG/cm ² for over 10 minutes, alarm.
40	High pressure sensor alarms	Pd>28.5kgG/cm ² for over 30 seconds
41	Suction temp. sensor TS alarm	TS>40°C for over 10 minutes
42	Current over-high	Signal is higher than setting Max. current for 5 seconds

43	Master discharge temp. sensor alarm in low frequency	When inverter compressor frequency is lower than 30Hz, TD1 is higher than 110°C
44	Communication error between master unit MB89F538 and MCU 807(indoor)	No signal for over 4 minutes
45	Communication error between master unit MB89F538 and MCU 807 (indoor) MB89F538 and 807 (central controller)	No signal from indoor unit or central controller for over 4 seconds
46	Communication error between master unit connecting board and inverter PCB	No signal for over 2 minutes
49	Master inverter drive PCB EEPROM error	EEPROM data is lost or installed in wrong way.
50	The total capacity of indoor units is too high	Total capacity of indoor units > outdoor capacity x 135%
51	Outdoor communication signal is lost	
52	Indoor units is over than 64 sets	
53	Central control address repeat	Check the address of all indoor units
54	Master unit oil temp. is over-low	In running, the temp. of compressor oil is lower than (ps+10) °C for 5 minutes
69	Slave unit is lost	Communication of slave unit error or switched off
70	Shortage of refrigeration	Only show diagnostic code, doesn't stop units

1.10 Weekly timer YCS-A001

The weekly timer is a special functional part for Haier Commercial Air Conditioner's remote monitoring system-group control function network (hereinafter abbreviated as group control network) and the user's optional part. Remote central controller (hereinafter abbreviated as central controller) achieves the coding and display of control data by its keystroke and LCD screen; connected to bus and executes the control to the air conditioner's basic functions by detector. Remote detector (hereinafter abbreviated as detector) is used to transform the standard digital interface to realize the communication of bus code sub-address; connected directly to air conditioner to execute local operation and collection to the control information and working information of air conditioner and to transmit the control and information data. Network air conditioner (hereinafter abbreviated as air conditioner) means the air conditioner, which indoor PCB possesses remote control interface. Only the network air conditioner can cooperate with detector, central controller and weekly timer, etc. parts to form the remote monitoring system-group control network and fulfill data exchange and monitoring function.

The function level of weekly timer and the central controller is the same. It can be checked by detector and displayed by LCD screen the trouble state and timing setting of air conditioner. It also can set the timing settings of the air conditioner within a week by keystroke input cooperating with LCD display. Weekly timer can be either used together with central controller or used independently (the detector is the essential part). Additionally, the weekly timer is equipped with 24-hour real-time clock system to unify the clocks in the group control network (the clocks in group control network and air conditioner are respectively independent and do not interfere with each other). The brief introductions are as follows:

1.Communication Function

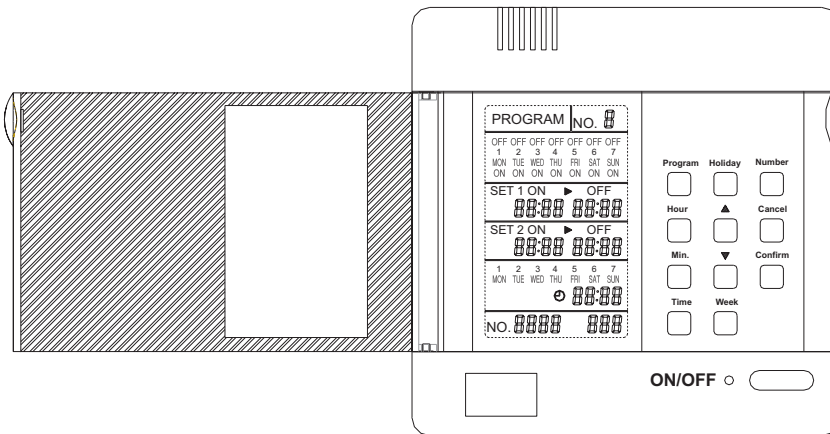

Communication with the detector of the group control network.
Executing communication with detector by RS-485 bus (A, B). The weekly timer sends a control command and communicates according to unified address; the execution of the command is delayed. The weekly timer can simultaneously monitors the trouble information sent from detector.

2.LCD function:

The LCD can display the weekly timing settings of the air conditioner (7 days a week and each day can set max two times of timer on and timer off),
The LCD can display the trouble code information of the air conditioner with trouble,The LCD can display the current time of the clock and weekday's information,
The LCD can display holiday setting, which is used to temporarily cancel the On function of the air conditioner.

3.Keystroke input function:

The keys used in normal state to adjust and confirm the clock and weekdays-time, Confirm, Cancel,
The key used for enter and quit from timing setting program state-program.
The keys used to switch programmed contents-Date, Hour, Minute.
The keys used to adjust the program contents--▲ , ▼
The keys used to whether accept the programmed contents or not-tConfirm, Cancel.
The key used in normal state to temporarily cancel the special date timing function-Holiday.

4.Unit number setting function:

In order to rich the control function of Haier Commercial Air Conditioner's remote monitoring system and be able to set multiple controllers combined use to fulfill the combination of multiple functions, the weekly timer is configured with two dial-code switches used to set the controller's addresses (the controller's addresses cannot be repeated in the same control network).

The weekly timer has its independent own power supply. Its communication interface is RS-485 interface, and the two-core screw fixed terminals (A, B) is connected with shielded twisted pair communication bus and set the address number different from those of other controllers.

1. Use weekly timer to realize weekly timing function:

The detector is connected with one air conditioner by the 4-core screw fixed terminals A+ and A- of air conditioner interface, then accordingly set the dial-code switch of the detector in single unit working mode; the address number setting shall be performed according the planned program, for specific setting and corresponding address, please refer to the dial-code switch setting in detector's operation manual; use weekly timer to fulfill weekly timing function, the system needs to be connected with weekly timer; each detector and weekly timer is connected with shielded twisted pair communication bus by the 2-core screw fixed terminals (A and B) of its RS-485 interface; the communication bus must be shielded and grounded, and the resistors in its two ends shall be suited.

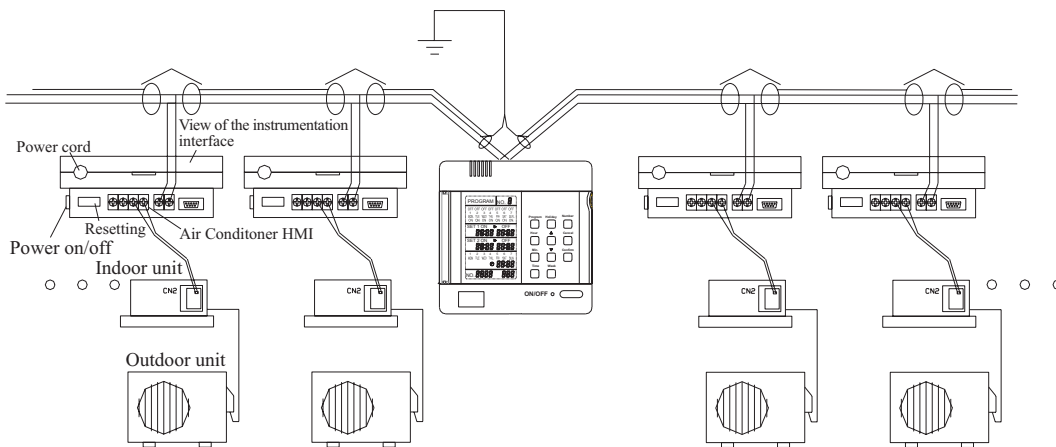

2. Use weekly timer to realize two units auto-changeover function:

The detector is connected with two same model air conditioners by the 4-core screw fixed terminals of air conditioner interface; then accordingly set the dial-code switch of the detector in double units working mode, and the double units switch time is default 24 hours; the address number setting shall be performed according the planned program, for specific setting and corresponding address, please refer to the dial-code switch setting in detector's operation manual; use weekly timer to fulfill double units switch weekly timing function, the system needs to be connected with weekly timer; each detector and weekly timer is connected with shielded twisted pair communication bus by the 2-core screw fixed terminals (A and B) of its RS-485 interface; the communication bus must be shielded and grounded, and the resistors in its two ends shall be suited.

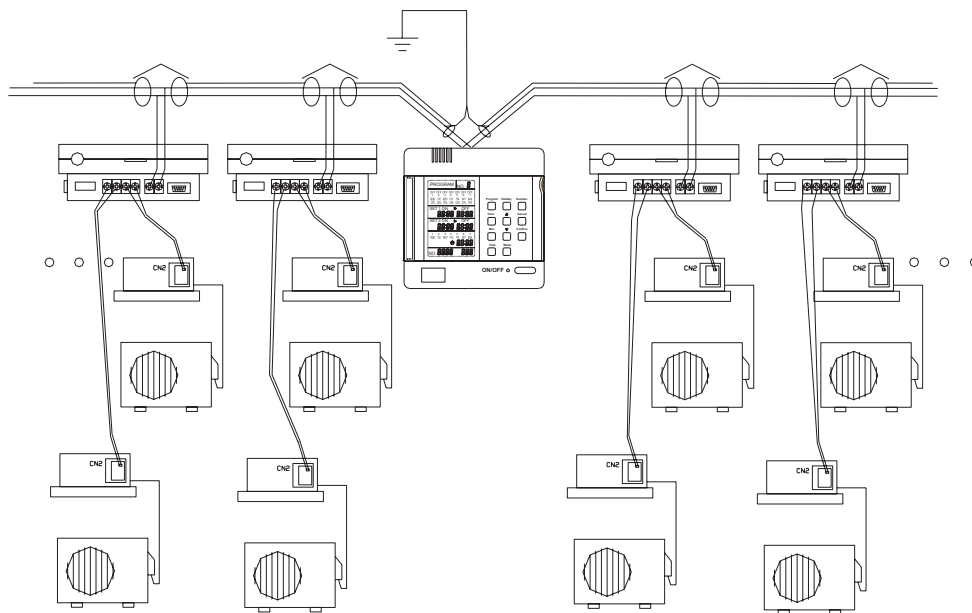

Caution:

Not all units can use detector, so for some units, they haven't auto changeover function.

3. Use central controller + weekly timer to realize the group control function + weekly timing function:

Please reference central controller manual.

4. Use central controller and weekly timer to realize auto-changeover + group control + weekly timing function:

Please reference central controller manual.

Instruction:

1 - PROGRAM-the display shows the weekly timer timing setting state, and in setting state, the timing information can be adjusted.

2 - No:8-timing group number: when it is not set timing, there is no timing group number; after setting timing, it will automatically form a group number according to each kind of setting combination, so that in the sequent timing setting, it can execute instant setting by using timing group number.

3 - Setting state and holiday functional area-1 (MON), 2 (TUE), 3 (WED), 4 (THU), 5 (FRI), 6 (SAT), 7 (SUN) are used to indicate the 7 days in a week; the symbol of this part will display after powered on; after set the corresponding weekday's timing function, the ON symbol

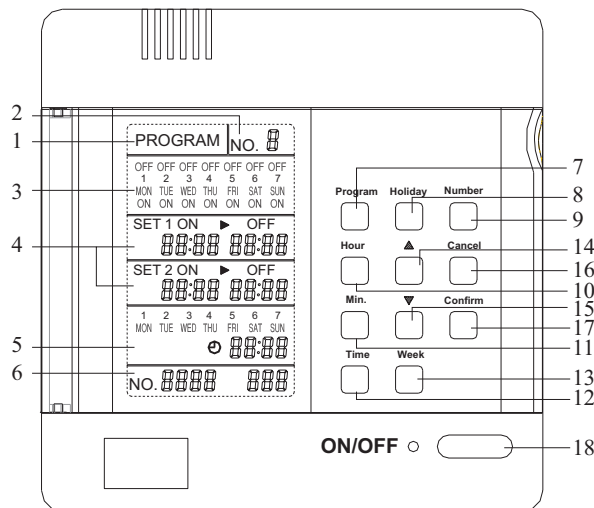

under the corresponding symbol will display, if not set timing, there will be no display; if not set Holiday function, the OFF symbol on the upside of the indicating symbol will not display, after set Holiday function, the OFF will display and at the same time temporarily the previous timing setting and turn off the air conditioner.

4 - No. 1 group and No.2 group timing setting display area-when entering timing setting state, the contents of timing will flash; choose Date, Hour and Minute to perform increase and decrease adjustment by the adjusting key.

5 - Time display area-including display the weekday, hour and minute; before setting timing function, please calibrate the current clock.

6 - Unit number trouble code display area-when the air conditioner in the control network has trouble, the corresponding unit number and the trouble code will display in this area.

7 - Program

Enter or exit the timing setting in normal condition,

8 - Holiday

Close the units and invalid for timing in no affect on the timing setting condition.

9 - Number

Group setting and timing setting (take one day as a standard unit)

10 - Hour

Timing setting condition and time setting condition ,select the adjustment

11 - Min.

Timing setting condition and time setting condition ,select the adjustment

12 - Time

Enter and exit the at present date and time condition in normal condition

13 - Week

Timing setting condition and time setting condition ,select the adjustment

14 -▲

Timing setting condition and time setting condition , increase the setting parameters

15 -▼

Timing setting condition and time setting condition , decrease the setting parameters

16 - Cancel

Cancel the present setting before confirm the parameter.

17 - Confirm

Confirm the parameter.

18 - ON/OFF

Open/close the unit.

1. Time adjusting function:

When powered on for the first time or after a long period of time
Press the Time key to enter time adjusting function;

- (1) Continuously press Week key can adjust the current date (weekday);
- (2) Press Hour key/Min. key to choose the contents to be adjusted, then use Increase key ▲ /Decrease key ▼ to adjust time;
- (3) Press Confirm key to confirm the above adjustment. After confirming and the time works in the adjusted time; or press Cancel key to cancel the adjustment and resume the previous state.

2. Timing data setting

- (1) Press Program key to enter timing data setting state;
 - (2) Press Week key to choose the program setting date;
 - (3) Press Hour key/Min. key to choose the contents to be adjusted, then use Increase key ▲ /Decrease key ▼ to adjust time;
 - (4) After finishing data setting, press Confirm key to confirm the setting and simultaneously switch to the next timing section; or press Cancel key to cancel the setting and resume the previous state; the weekly timer can set two groups of Timer On/Off per day;
 - (5) After finishing the data setting for a whole day, the controller will automatically distribute a time number. In the sequent setting, if use the same timing setting data, only choose the date to be set and choose the Number key, then press Confirm key;
- Press Program key again to quit from the timing data setting state.

3. Holiday setting function:

- (1) Press Holiday key to enter holiday setting function state;
 - (2) Press Week key to choose the date to set as holiday;
 - (3) Press Confirm key to confirm the set holiday function, and simultaneously OFF will display on the top of the current date;
 - (4) If set multi-days as holiday, repeat the above operation till it is complied with requirements;
- Holiday setting function is only valid in timing setting function. Weekly timer can display the malfunction unit number having trouble (the same as detector setting address number) and the following trouble code. The corresponding meaning of the trouble code are as the follow table show (including air conditioner trouble and group control network trouble):

D4	D3	D2	D1	D0	Code	Meaning
0	0	0	0	0	—	No trouble(working normally)
0	0	0	0	1	1	Indoor ambient temperature sensor abnormal
0	0	0	1	0	2	Indoor pipe temperature sensor abnormal
0	0	0	1	1	3	Indoor heating overload protection
0	0	1	0	0	4	Indoor cooling freezing (overload) protection
0	0	1	0	1	5	Indoor unit and outdoor unit communication abnormal
0	0	1	1	0	6	Panel (wire controller) and indoor unit communication trouble (air conditioner displays, central control displays 30)
0	0	1	1	1	7	Module abnormal (PFC protection-DC)
0	1	0	0	0	8	No load
0	1	0	0	1	9	Compressor overheat
0	1	0	1	0	10	CT current abnormal
0	1	0	1	1	11	Outdoor ambient temperature abnormal
0	1	1	0	0	12	Outdoor heat exchanger (pipe temperature) sensor abnormal
0	1	1	0	1	13	Power supply excess/lack voltage protection
0	1	1	1	0	14	High pressure protection
0	1	1	1	1	15	---Outdoor evaporator sensor abnormal
1	0	0	0	0	16	---Cooling overload
1	0	0	0	1	17	EEPROM abnormal
1	0	0	1	0	18	Outdoor return air sensor abnormal
1	0	0	1	1	19	Compressor sensor abnormal
1	0	1	0	0	20	---Indoor evaporator sensor abnormal
1	0	1	0	1	21	Drainage system abnormal
1	0	1	1	0	22	Power supply 3-phase abnormal (lack phase or wrong phase)
1	0	1	1	1	23	Humidity sensor abnormal
1	1	0	0	0	24	Indoor fan motor abnormal (fan motor over-current, fan motor IPM protection, fan motor Hall components abnormal)
1	1	0	0	1	25	Outdoor fan motor abnormal (fan motor over-current, fan motor IPM protection, fan motor Hall components abnormal)
1	1	0	1	0	26	Low pressure protection
1	1	0	1	1	27	---Electronic expansion valve abnormal
1	1	1	0	0	28	---Dust removing filter needs to be cleaned
1	1	1	0	1	29	Refrigerant is insufficient
1	1	1	1	0	30	Detector and air conditioner communication abnormal
1	1	1	1	1	31	Abnormal communication with the bus of detector

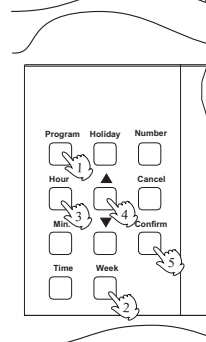
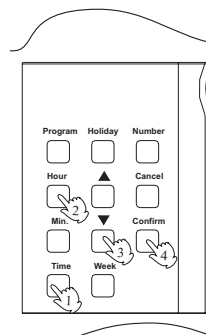

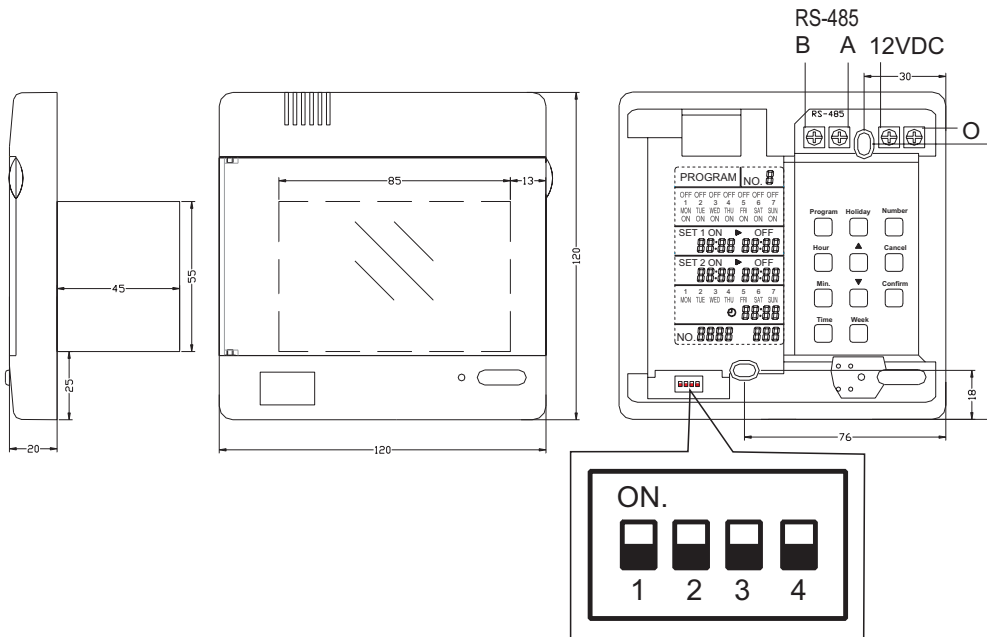

Installation and Debugging

1. The long-distance monitoring system group control network (hereinafter abbreviated as group control network) of Haier Commercial Air Conditioner must establish, from its design plan, installation and debugging to after-sale-service, a complete set of documents (group control network programming, installation record, debugging record and repair and maintenance record) and keep in the archives for future use.

2. The programming of group control network needs to finish the following works in advance, including: (1) Composition of group control network system and control number; (2) Choose the model of air conditioner, installation position, power distribution and wiring treatment and connection with detector;

(3) Installation position of detector, address and unit number distribution, power distribution and wiring treatment, connection with group control bus; (4) Installation and wiring of group control bus, bus length limitation, the matched resistors at the two ends of bus, the shielded layer of bus shall be single-point grounded; (5) Installation position of central controller, address unit number distribution, power distribution and wiring treatment.

3. The programming principle of group control network: (1) Detector is the essential part; in order to guarantee proper response speed and reliable communication, the number of detector equipped on the central controller shall not exceed 64; (2) The air conditioner must be network air conditioner, and the installation must be performed according to the attached operation and installation manual; in test run, cancel the air conditioner's Power Failure Resume function; (3) It is recommended do not use the double units switch function of the detector in the big load circumstance, that is it must be equipped with group control network double units switch function, which requires the model of the used air conditioners must be the same and the installation space is half of the general installation space; (4) The installation position of the detector shall not be too far from the air conditioner and shall not exceed the length of the connecting wire; (5) The detector address unit number must be strictly distributed in the increasing sequence and set the successive unit number; (6) Detector power distribution: the wiring shall not be too close to the communication wire or pass through the same wire channel; no other special requirements; (7) Connection of detector and group control bus: it is not allowed to connect additional branch wire to the group control bus; (8) The shielded wire of detector's air conditioner communication wire is short connected with the shielded wire of detector's central controller communication wire; (9) The wiring of group control bus shall not be too near the connecting wire or pass through the same wire channel; the rest can refer to the wiring requirements of the storied building's auto control system; (10) The total length of group control bus limits in 1000m; (11) At the ends of the bus and between A bus and B bus shall respectively connect a 100Ω metal film precise resistor; address unit number of central controller and weekly timer shall not be repeated;

(12) The bus shielded wire is single-point grounded. It is recommended to arrange it in the middle part of the bus and near central controller or weekly timer; (13) The installation position of central controller or (and) weekly timer arrange in the middle part of the bus in principle and near the communication bus shielded grounding wire; (14) The address unit number of central controller is set as default; the address unit number of weekly timer is set as default; the central controller unit No. can't be the same as that of the weekly timer. (15) The central controller is in its own separate wiring circuit; the wiring circuit and the communication circuit shall not be too close or pass the same channel; no other special requirements; (16) The weekly timer uses 12VDC power supply, which can be directly connected from the neighboring detector or connected with other DC12V power supply; (17) Weekly timer can cooperatively use together with central controller as a controller, or use weekly timer separately as the only controller.

4. The wiring and installation of group control network will be done synchronously together with the installation and debugging of network air conditioner. Please perform test run before installation.

5. Connection of detector and air conditioner: The working mode and address unit number of detector shall be performed strictly in line with the planned programming; detector executes wire communication with at most two sets of air conditioners by the air conditioner interface 4-core screw fixed terminals (A+, A-, B+, B-); the connection of detector and air conditioner shall use the same wire; the inserted terminal at one end of the wire is connected with the remote control interface on the air conditioner PCB, the core wire at the other end of the wire is respectively connected with A+, A- (B+, B-); the connection has polarity: generally the white wire connects A+/B+, black wire/red wire connects A-/B-; in debugging, if the detector cannot work normally, it can be checked by exchange between + pole and + pole. In powered on debugging, it can also use the operation state displayed by the operation light (green LBD) to determine whether the air conditioner communication interface is normal.
6. After finishing the wiring work of communication bus, perform the connection between detector bus and communication bus: multiple detectors are parallel connected with communication bus; all the A interfaces (including central controller or weekly timer) are in the same bus; all the B interfaces (including central controller or weekly timer) are in the other same bus; A interface wire and B interface wire at the end of the communication bus is respectively connected a 100Ω metal film precise resistor; the communication bus shielded wire is single point grounded in the middle part; the total length of communication bus is limited in 1000m.
7. After finishing installation and connection of detector, perform central controller or weekly timer connection with communication bus: central controller or weekly timer connects with communication bus by RS-485 interface 2-core screw fixed terminals (A, B); the connecting position is in the middle part of communication bus and near the grounded point of its shielded wire.
8. Powered on debug: after powered on, the central controller will circularly monitor the detectors and air conditioners in the communication bus. After searching a period of time, the unit number shall expectedly display. If abnormal, perform check and debug.
9. After finishing debugging of central controller, powered on weekly timer. If at this time appears disorderly communication, please check the address setting of weekly timer and central controller. If communication normal, perform clock calibration and timing setting. After the timing function achieves, finally perform Holiday function checking.
10. After debugging, record the debugging process, and after training the personnel, deliver the engineering.
11. Setting of central controller's dial-code switch: if the dial-code switch is in OFF position, indicates 0; if in ON position, indicates 1. For the address number setting, please refer to the following table:

No.	D3, D4
1	0 0
2	0 1
3	1 0
4	1 1

Note: D1, D2 not used

Performance Parameter and Fittings

Power supply	1PH DC12V / AC220V
Power consumption	2W
Max dimension	120x120x68
Weight	520g
Fittings	Power supply connecting wire

User's Self-provide Parts

User's self-provide parts:

Group control bus: Recommend to use UL2547 type or equivalent type twisted-pair shielded wire, and the specification is no less than AWG20 (UL2547-202).

1.11 Detector YCJ-A001

Safety Precautions

Below are four kinds of safety precautions and suggestions:





- ⚠ **WARNING:** Improper use may result in severe consequences of death or serious injures.
- ⚠ **CAUTION:** Improper use may result in injures or machine damages; in some cases may cause serious consequences
 - ⊘ : It must be strictly prohibited where marked with “Prohibited”, otherwise may result in machine damages or endanger the user’ personal safety.
 - ❗ : It must be strictly followed where marked with “To be followed”, otherwise may result in machine damages or endanger the user’ personal safety.



Instructions: This information can ensure correct operation of the machine.

Be sure to follow the following important safety precautions.

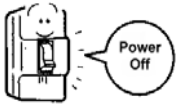
These precautions should be at hand to be checked at any time when needed.

If air conditioner is transferred to a new user, this manual should be as well transferred to the new user.

WARNING	
<ul style="list-style-type: none"> • Entrusting Installation Installation should be entrusted to after service staff; self-installation may result in electric shock, fire and the similar because of improper installation.  If any abnormal phenomena are found (e.g. smell of burning), please stop running and cut off power supply, and contact after service staff to find out treatment method.  If keep using under this situation, may result in accident of electric and fire.  <div style="text-align: right; margin-top: 10px;">  </div>	<ul style="list-style-type: none"> • When intend to move and reset controller, ask after service staff for responsibility. Improper installation may result in electric shock and fire. • Absolutely not to alter without authorization. Improper alteration may result in accident of electric shock, fire and the similar. • When repair needed, ask after service staff to handle it. Improper maintenance and repair may result in electric shock and fire. 

 CAUTIONS	<ul style="list-style-type: none"> • Not be allowed to spray flammable spraying agent directly to controller. Otherwise may result in fire. • Not be allowed to operate switch with damp hands, and not to spray controller with water. Otherwise may result in electric shock. • Not be allowed to press switch with matter having sharp tip. Otherwise may result in malfunction or electric shock. <div style="text-align: right; margin-top: 10px;"></div>
--	--

<p style="text-align: center;">Maintenance</p> <ul style="list-style-type: none"> • When maintenance or abnormity appeared, be sure to cut off manual operation power. • It will cause color change or paint-fading if wipe appearance of operation portion with gasoline, thinner or chemical wiping cloth; be careful. If operation portion is heavily soiled, shall immerse cloth in diluted neutral detergent, and wipe that portion after wring the cloth, and wipe cleanly with dry cloth. <div style="text-align: right; margin-top: 10px;"></div>

Abstract of Function

Remote control detector (hereunder as: detector) is the necessary part and user's optional part of Haier commercial air conditioner remote monitor and control system. Net air conditioner (hereunder as: air conditioner or remote) means a air conditioner with remote control interface on indoor computer board, onlu which could combine with parts such as detector and central controller to form remote or detector interface monitor and control system.

Detector is a key part of Haier commercial air conditioner remote monitor and control system, used for transferring standard digital interface to realize communication between bus code and sub-address. It is connected directly to air conditioner to realize local operation and collection of control information and working information of air conditioner. Together with air conditioner central controller (hereunder as: central controller) and air conditioner, form the Haier commercial air conditioner remote monitor and control system — group control function network to realize data exchange and monitoring. Abstract description as follows:

A. Communication Function

1. Communication with air conditioner

Perform wire communication with at most two air conditioners through 4-poles screw-fixing terminal, and can realize two-unit switchover function when connected to two air conditioners, which control operation status of air conditioner by different ways according to inner control or inquiry demand of detector, and check working information and malfunction information of air conditioner at the same time.

2. Communication with central controller (another optional accessory, a control component of Haier commercial air conditioner remote monitor and control system)

Realize communication with central controller through RS-485 interface bus. According to the components number set by internal dialing switch, receive commands from central controller, form internal control or enquiry request of detector and answer reception status and working information and malfunction information of air conditioner.

B. Power Failure Resume

To reduce the impaction to power network when air conditioners simultaneously start, detector have power blackout compensation function to replace the power blackout compensation function of local air conditioner when use group control net; When power restored after blackout, air conditioner can automatically restart with different delay according to basic running status before power blackout.

C. Two-unit Switchover Function

To increase operation reliability of air conditioner, detector is equipped with two-unit switchover function, and the internal dialing switch of detector set single-unit operation mode or two-unit switchover mode. When select single unit mode, detector controls unit A according to commands from previous unit. When select two-unit mode, unit A and unit B have absolutely equal position in realizing two-unit switchover function.

Abstract of Function

Realization of two-unit switchover function: in normal operation status, one air conditioner is started to operate under the control of detector and another one stops to wait, when it's time for switchover the detector wakens the waiting air conditioner and recalculates time, and the previous running one will continue to operate and automatically stops to wait half hour later. If any of air conditioner fails to function, switchover timing is temporally stopped, the detector is automatically controlled to waken another air conditioner and after that stop the malfunction one to wait status. The detector will forward transfer the malfunction information when inquiring and automatically restore two-unit switchover function after malfunction is removed. If air conditioner cannot reach the setting temperature after a period of running, that is over-load, switchover timing will be temporally stopped, the detector is automatically controlled to waken another air conditioner and two units operate together until the setting temperature is obtained, now automatically stop the latter started conditioner and restore two-unit switchover function automatically.

D. Unit Number Setting Function

There is a 8-bit dialing switch inside the detector, the highest order is D8 used for setting single unit operation mode or two-unit switchover operation mode; lower seven bits (D7, D6, D5, D4, D3, D2 and D1) are used for setting unit number (group control network) or two-unit switchover time (two-unit switchover).

E. Working Status Display Function

Detector indicators are divided into power indicator (red LED) and operation indicator (green LED): the operation indicator has the function of displaying operation status, and the power indicator lights if power is normal after power on; lit operation indicator means that detector works normally, and flashed operation indicator shows operation status of detector and distinguishes the meaning of different status by flashing times.

F. Time Delay Control Function

When forming central control network through RS-485 bus, detector sets start delay function to reduce impaction to power network because of simultaneous control and operation of air conditioners, and delay time is created by detector randomly and automatically.

G. Detector can only be used for some of Haier Commercail indoor type , for example: Free Multi Wall mounted type, Console type etc. Detector is necessary for Weekly timer or central controller installation for this types. But Duct type, Cassette type, Convertible type couldn't use detector., they can directly be connected with weekly timer or central controller.

Introduction of System

1. Only use two-unit switchover function

Detector is connected to two air conditioners with same type through a 4-poles screw-fixing terminal at the interface of air conditioner, and correspondingly set dialing switch of the detector as two-unit switchover operation mode. When only use two-unit switchover function, system do not need to connect other parts. Two-unit switchover time can be set within the range of 1-127 hours by the low 7 bits of dialing switch, see dialing switch setting table for detail settings and corresponding times.

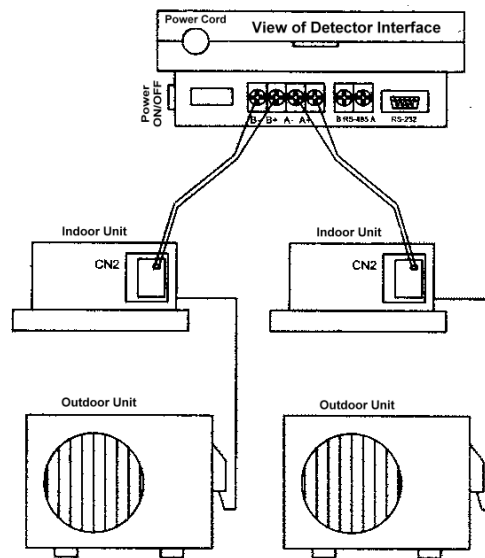

2. Use central controller to realize group control function

Please reference “Central controller YCZ-A001 manual” and “Weekly timer YCS-A001 manual”.

3. Use central controller to realize two-unit switchover group control function

Please reference “Central controller YCZ-A001 manual” and “Weekly timer YCS-A001 manual”.

Maintenance

Status Inspection

- Control unit A when select single unit, and when unit A fails to function, detector will forward transfer malfunction information during inquiry. Control unit A and B when select two units, as long as one air conditioner fails to function, detector will forward transfer malfunction information during inquiry.
- Display of detector running status and operation indicator: 0.5 second ON and 0.5 second OFF of operation indicator is a cycle, and indicate information using times of the cycle, which form status indication, and an interval of 2 seconds between status indication and status indication. Detector puts all detected status together to form a status indication cycle, and an interval of 4 seconds between status indication and status indication. For example: under two-unit status, there is an air conditioner interface communication error, then indication 2 + 2 seconds waiting + indication 3 + 4 seconds waiting and recycles like this.

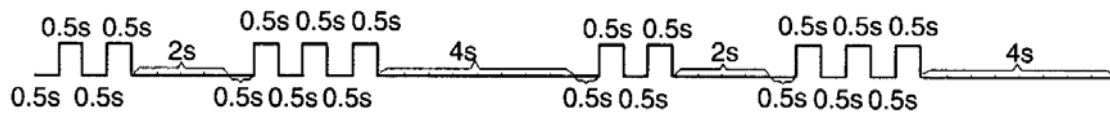

Serial No.	Flashing times	Meaning
1	1	Communication error with previous unit interface RS-485
2	2	Communication error with previous unit interface RS-232C
3	3	Communication error with interface of air conditioner A
4	4	Communication error with interface of air conditioner B (do not check this interface under single unit status)
5	5	Data error of detector's EEPROM
6	6	Data collection of air conditioner cannot inquiry and confirms error.
7	7	Control commands from previous unit cannot be performed.

Be sure to cut off manually controlled power supply switch when maintenance.

- Wipe with a soft dry cloth. If too dirty, immerse cloth in diluted neutral detergent and wipe after wring the cloth, and clean with dry cloth.
- Forbid to wipe with gasoline, thinner, household cleanser or chemical wiping cloth, otherwise may result in color change, paint-fading, deformation or break.

Appearance, Dimension and Interface

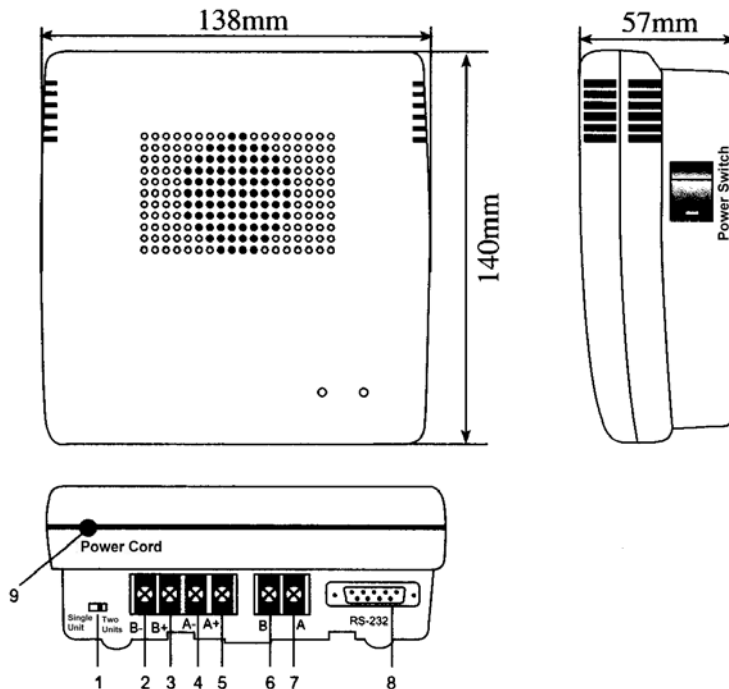

- 1----- Reset Port
- 2----- Signal Ground Wire of Unit B
- 3----- Signal Line of Unit B
- 4----- Signal Ground Wire of Unit A
- 5----- Signal Line of Unit A
- 6----- Central Control Interface — B
- 7----- Central Control Interface — A
- 8----- Communication Line for RS-232 Linking Control Computer or Communication Line of MODEM (We only offer agreement of detector for programming control software)
- 9----- Power Cord. If damaged, to avoid dangers, the power cord must be replaced by manufacturer or its maintenance department or similar professional staff.

Performance Parameters and Accessories

Power Supply	1PH, 220~230VAC, 50Hz
Consumed Power	3W
The Maximum Dimension	139 × 142 × 55 mm
Weight	0.53 kg
Accessories	2 pieces of communication line to air conditioner (UL2547, AWG24 2C) (Core: red/white)

Installation and Debugging

Installation Methods

Fix detector by means of two screws hanging methods, and distance between screws see (right figure).

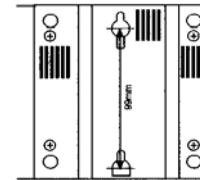

1. Realization, installation, wiring and power distribution of a system only using two-unit switchover function are much more easier, after finishing installation of two units, connect detector to the remote control interface of the air conditioner computer board, set detector as two-unit switchover working mode and set two-unit switchover time as required.
2. It must form a complete set of documents (project layout for group control network, installation and construction records for group control network, debugging records for group control net, maintenance and repair records for group control network) for group control network of Haier commercial air conditioner long distance system (hereinafter for short as: group control network) from layout design, installation, debugging to after service, and file all for future reference.
3. Layout design of group control net work shall be finished in advance, including: (1) compositions of group control network system and quantities controlled; (2) selection type of air conditioner, installation place, power distribution and wiring manner and connection to detector; (3) installation place of detector, allocation of unit address code, power distribution and wiring manner and connection to group control bus; (4) installation and wiring of group control bus, length limitation of bus, resistance matching of two ends of bus, and single point earth of bus shielding layer; (5) installation place of central controller, allocation of unit address code, power distribution and wiring manner.
4. Principles of layout design of group control net: (1) detector is essential part, to keep proper responding speed and communication reliability, detector quantities carried by one central controller shall not more than 64; (2) air conditioner must be a net air conditioner, installation must strictly follow the installation and operation instructions shipped with the unit, and confirm that power blackout compensation function of local air conditioner has been cancelled when debugging; (3) suggest that do not use two-unit switchover function of detector in the case of high load, i.e. suggest that do not use one detector to load two air conditioners when detector forming group control net, otherwise temperature difference control may be affected. If it is necessary to install two-unit switchover function for group control net, air conditioners with same type and half installation distance of that of normal installation are required; (4) installation place of detector shall not too far away from air conditioner, not exceed the wiring length; (5) unit address code of detector shall be strictly allocated in a sequence from small one to big one, and set continuous unit number; (6) for power distribution of detector, the power distribution line and communication line shall not be too close from each other or in the same wiring channel, and no other special requirements; (7) for connection between detector and group control bus, not allowed to connect branch line from the group control bus; (8) shielding line of communication line between detector and air conditioner and the shielding line of communication bus between detector and central controller shall be shorted; (9) wiring and power distribution line of the group control bus shall not be too close from each other or in the same wiring channel, and others may refer to wiring requirements of building autocontrol system; (10) limit the total length of group control bus to 1000 meters; (11) at both ends between Bus A and Bus B connect a metallic membrane precision resistance of 100 or 120 ohm respectively; if needed (12) single point earth for bus shielding line, suggest to be arranged in the middle of communication bus, close to central controller;

Installation and Debugging

- (13) in principle, installation place of central controller shall be arranged in the middle of communication bus, close to shielding earth line of communication bus; (14) unit address codes of central controller adopt the default settings; (15) central controller has its own power distribution line, the power distribution line and communication line shall not be too close from each other or in the same wiring channel, and no other special requirements.
5. Installation and construction of wiring of group control network shall be processed together with installation and debugging of net air conditioner, pay attention to commissioning before installation.
 6. Connection between detector and air conditioner: detector working mode and unit address code shall be strictly set according to planned layout; detector makes wire communication with at most two air conditioners (A, B) through 4-poles screw-fixing terminal at air conditioner interface (A₊, A₋, B₊, B₋); connection between detector and air conditioner use uniform wiring; use uniform wiring for connection between detector and air conditioner, one plug in type terminal of wiring connected to Remote control interface on the computer board of air conditioner, and cores of another terminal respectively connected to A₊ and A₋ (B₊ and B₋); connection has polarity, and generally white wire connected to A₊/B₊ and black/red wire connected to A₋/B₋; if detector cannot work normally when debugging, then can check and remove malfunction by changing positive and negative polarity. During debugging also can judge whether communication interface to air conditioner is normal according to the running status indicated by operation indicator (green LED).
 7. Connect detector and communication bus after finish the wiring of communication bus: connect several detectors to communication bus in parallel, all terminal port A (including central controller) on one bus, and all terminal port B (including central controller) on another bus, at both ends of the communication bus - A terminal port line and B terminal port line shall paralleling connect a metal membrane precision resistance of 100 or 120 ohm respectively if needed. Earth one point of the shielding line of communication bus, which is at the middle position of the communication bus, and the total length of communication bus shall be limited within 1000m.
 8. Connect central controller and communication bus after finish installation and connection of detector: central controller is connected to communication bus through the 2-post screw-fixing terminal (A and B) of interface RS-485, locating in the middle of the communication bus, with position close to the earth point of the shielding line of communication bus.
 9. Power on and debugging: after power on, central controller periodically monitors the detector and air conditioner groups on the communication bus, and after inquiring for a period of time the unit number shall display as expected, check and debug if having any difference.
 10. Set the dialing switch of detector: (1) there is a 8-bit (1~8) dialing switch inside the detector, OFF means 0 and ON means 1; (2) the eighth bit used for setting single unit working mode or two-unit switchover working mode, OFF means single unit and ON means two-unit; (3) the lower seven bits (from the seventh to the first bit) have up to 128 selections when forming group control net, which are used for setting unit address code, see the table below for detail setting check list; (4) the lower seven bits have up to 128 selections when forming group control net and using two-unit switchover function, which are used for setting unit address code, see the table below for detail setting check list, and the default two-unit switchover time is 24hrs; (5) the lower seven bits have up to 128 selections when not forming group control net, which are used for setting two-unit switchover time, see the table below for detail setting check list.

Installation and Debugging

Two Unit NO.8	Dialing setting (1 means dialing to ON, 0 means dialing to OFF)							Low 7-bit value	Air conditioner installation sequence	Unit number of central controller	Two-unit switchover time
	NO.7	NO.6	NO.5	NO.4	NO.3	NO.2	NO.1				
*	0	0	0	0	0	0	0	0	1	1-1	No limit
*	0	0	0	0	0	0	1	1	2	1-2	1hr
*	0	0	0	0	0	1	0	2	3	1-3	2hrs
*	0	0	0	0	0	1	1	3	4	1-4	3hrs
*	0	0	0	0	1	0	0	4	5	1-5	4hrs
*	0	0	0	0	1	0	1	5	6	1-6	5hrs
*	0	0	0	0	1	1	0	6	7	1-7	6hrs
*	0	0	0	0	1	1	1	7	8	1-8	7hrs
*	0	0	0	1	0	0	0	8	9	1-9	8hrs
*	0	0	0	1	0	0	1	9	10	1-10	9hrs
*	0	0	0	1	0	1	0	10	11	1-11	10hrs
*	0	0	0	1	0	1	1	11	12	1-12	11hrs
*	0	0	0	1	1	0	0	12	13	1-13	12hrs
*	0	0	0	1	1	0	1	13	14	1-14	13hrs
*	0	0	0	1	1	1	0	14	15	1-15	14hrs
*	0	0	0	1	1	1	1	15	16	1-16	15hrs
*	0	0	1	0	0	0	0	16	17	2-1	16hrs
*	0	0	1	0	0	0	1	17	18	2-2	17hrs
*	0	0	1	0	0	1	0	18	19	2-3	18hrs
*	0	0	1	0	0	1	1	19	20	2-4	19hrs
*	0	0	1	0	1	0	0	20	21	2-5	20hrs
*	0	0	1	0	1	0	1	21	22	2-6	21hrs
*	0	0	1	0	1	1	0	22	23	2-7	22hrs
*	0	0	1	0	1	1	1	23	24	2-8	23hrs
*	0	0	1	1	0	0	0	24	25	2-9	24hrs
*	0	0	1	1	0	0	1	25	26	2-10	25hrs
*	0	0	1	1	0	1	0	26	27	2-11	26hrs
*	0	0	1	1	0	1	1	27	28	2-12	27hrs
*	0	0	1	1	1	0	0	28	29	2-13	28hrs
*	0	0	1	1	1	0	1	29	30	2-14	29hrs
*	0	0	1	1	1	1	0	30	31	2-15	30hrs
*	0	0	1	1	1	1	1	31	32	2-16	31hrs
*	0	1	0	0	0	0	0	32	33	3-1	32hrs
*	0	1	0	0	0	0	1	33	34	3-2	33hrs
*	0	1	0	0	0	1	0	34	35	3-3	34hrs
*	0	1	0	0	0	1	1	35	36	3-4	35hrs
*	0	1	0	0	1	0	0	36	37	3-5	36hrs
*	0	1	0	0	1	0	1	37	38	3-6	37hrs
*	0	1	0	0	1	1	0	38	39	3-7	38hrs
*	0	1	0	0	1	1	1	39	40	3-8	39hrs
*	0	1	0	1	0	0	0	40	41	3-9	40hrs
*	0	1	0	1	0	0	1	41	42	3-10	41hrs
*	0	1	0	1	0	1	0	42	43	3-11	42hrs
*	0	1	0	1	0	1	1	43	44	3-12	43hrs
*	0	1	0	1	1	0	0	44	45	3-13	44hrs
*	0	1	0	1	1	0	1	45	46	3-14	45hrs
*	0	1	0	1	1	1	0	46	47	3-15	46hrs
*	0	1	0	1	1	1	1	47	48	3-16	47hrs
*	0	1	1	0	0	0	0	48	49	4-1	48hrs
*	0	1	1	0	0	0	1	49	50	4-2	49hrs
*	0	1	1	0	0	1	0	50	51	4-3	50hrs
*	0	1	1	0	0	1	1	51	52	4-4	51hrs
*	0	1	1	0	1	0	0	52	53	4-5	52hrs
*	0	1	1	0	1	0	1	53	54	4-6	53hrs
*	0	1	1	0	1	1	0	54	55	4-7	54hrs
*	0	1	1	0	1	1	1	55	56	4-8	55hrs
*	0	1	1	1	0	0	0	56	57	4-9	56hrs
*	0	1	1	1	0	0	1	57	58	4-10	57hrs
*	0	1	1	1	0	1	0	58	59	4-11	58hrs
*	0	1	1	1	0	1	1	59	60	4-12	59hrs

Installation and Debugging

Two Unit NO.8	Dialing setting (1 means dialing to ON, 0 means dialing to OFF)							Low 7-bit value	Air conditioner installation sequence	Unit number of central controller	Two-unit switchover time
	NO.7	NO.6	NO.5	NO.4	NO.3	NO.2	NO.1				
*	0	1	1	1	1	0	0	60	61	4-13	60hrs
*	0	1	1	1	1	0	1	61	62	4-14	61hrs
*	0	1	1	1	1	1	0	62	63	4-15	62hrs
*	0	1	1	1	1	1	1	63	64	4-16	63hrs
*	1	0	0	0	0	0	0	64	65	5-1	64hrs
*	1	0	0	0	0	0	1	65	66	5-2	65hrs
*	1	0	0	0	0	1	0	66	67	5-3	66hrs
*	1	0	0	0	0	1	1	67	68	5-4	67hrs
*	1	0	0	0	1	0	0	68	69	5-5	68hrs
*	1	0	0	0	1	0	1	69	70	5-6	69hrs
*	1	0	0	0	1	1	0	70	71	5-7	70hrs
*	1	0	0	0	1	1	1	71	72	5-8	71hrs
*	1	0	0	1	0	0	0	72	73	5-9	72hrs
*	1	0	0	1	0	0	1	73	74	5-10	73hrs
*	1	0	0	1	0	1	0	74	75	5-11	74hrs
*	1	0	0	1	0	1	1	75	76	5-12	75hrs
*	1	0	0	1	1	0	0	76	77	5-13	76hrs
*	1	0	0	1	1	0	1	77	78	5-14	77hrs
*	1	0	0	1	1	1	0	78	79	5-15	78hrs
*	1	0	0	1	1	1	1	79	80	5-16	79hrs
*	1	0	1	0	0	0	0	80	81	6-1	80hrs
*	1	0	1	0	0	0	1	81	82	6-2	81hrs
*	1	0	1	0	0	1	0	82	83	6-3	82hrs
*	1	0	1	0	0	1	1	83	84	6-4	83hrs
*	1	0	1	0	1	0	0	84	85	6-5	84hrs
*	1	0	1	0	1	0	1	85	86	6-6	85hrs
*	1	0	1	0	1	1	0	86	87	6-7	86hrs
*	1	0	1	0	1	1	1	87	88	6-8	87hrs
*	1	0	1	1	0	0	0	88	89	6-9	88hrs
*	1	0	1	1	0	0	1	89	90	6-10	89hrs
*	1	0	1	1	0	1	0	90	91	6-11	90hrs
*	1	0	1	1	0	1	1	91	92	6-12	91hrs
*	1	0	1	1	1	0	0	92	93	6-13	92hrs
*	1	0	1	1	1	0	1	93	94	6-14	93hrs
*	1	0	1	1	1	1	0	94	95	6-15	94hrs
*	1	0	1	1	1	1	1	95	96	6-16	95hrs
*	1	1	0	0	0	0	0	96	97	7-1	96hrs
*	1	1	0	0	0	0	1	97	98	7-2	97hrs
*	1	1	0	0	0	1	0	98	99	7-3	98hrs
*	1	1	0	0	0	1	1	99	100	7-4	99hrs
*	1	1	0	0	1	0	0	100	101	7-5	100hrs
*	1	1	0	0	1	0	1	101	102	7-6	101hrs
*	1	1	0	0	1	1	0	102	103	7-7	102hrs
*	1	1	0	0	1	1	1	103	104	7-8	103hrs

Installation and Debugging

Two Unit	Dialing setting (1 means dialing to ON, 0 means dialing to OFF)							Low 7-bit value	Air conditioner installation sequence	Unit number of central controller	Two-unit switchover time
	NO.8	NO.7	NO.8	NO.7	NO.8	NO.7	NO.8				
*	1	1	0	1	0	0	0	104	105	7-9	104hrs
*	1	1	0	1	0	0	1	105	106	7-10	105hrs
*	1	1	0	1	0	1	0	106	107	7-11	106hrs
*	1	1	0	1	0	1	1	107	108	7-12	107hrs
*	1	1	0	1	1	0	0	108	109	7-13	108hrs
*	1	1	0	1	1	0	1	109	110	7-14	109hrs
*	1	1	0	1	1	1	0	110	111	7-15	110hrs
*	1	1	0	1	1	1	1	111	112	7-16	111hrs
*	1	1	1	0	0	0	0	112	113	8-1	112hrs
*	1	1	1	0	0	0	1	113	114	8-2	113hrs
*	1	1	1	0	0	1	0	114	115	8-3	114hrs
*	1	1	1	0	0	1	1	115	116	8-4	115hrs
*	1	1	1	0	1	0	0	116	117	8-5	116hrs
*	1	1	1	0	1	0	1	117	118	8-6	117hrs
*	1	1	1	0	1	1	0	118	119	8-7	118hrs
*	1	1	1	0	1	1	1	119	120	8-8	119hrs
*	1	1	1	1	0	0	0	120	121	8-9	120hrs
*	1	1	1	1	0	0	1	121	122	8-10	121hrs
*	1	1	1	1	0	1	0	122	123	8-11	122hrs
*	1	1	1	1	0	1	1	123	124	8-12	123hrs
*	1	1	1	1	1	0	0	124	125	8-13	124hrs
*	1	1	1	1	1	0	1	125	126	8-14	125hrs
*	1	1	1	1	1	1	0	126	127	8-15	126hrs
*	1	1	1	1	1	1	1	127	128	8-16	127hrs

12 Connecting board IGU04 0010451976

IGU04 detector is used with ICR01 central controller, IGU04 appearance and dimension is same with detector YCJ-A001

12.1 Appearance

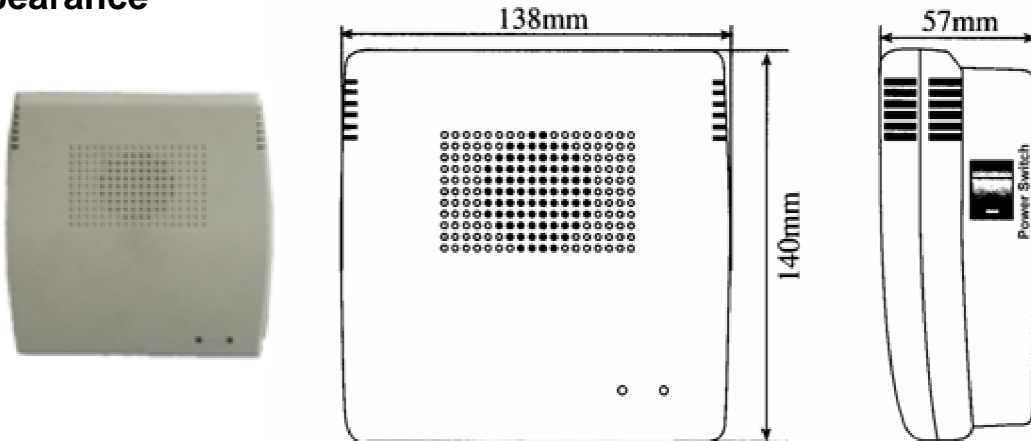

12.2 PCB photo and drawing

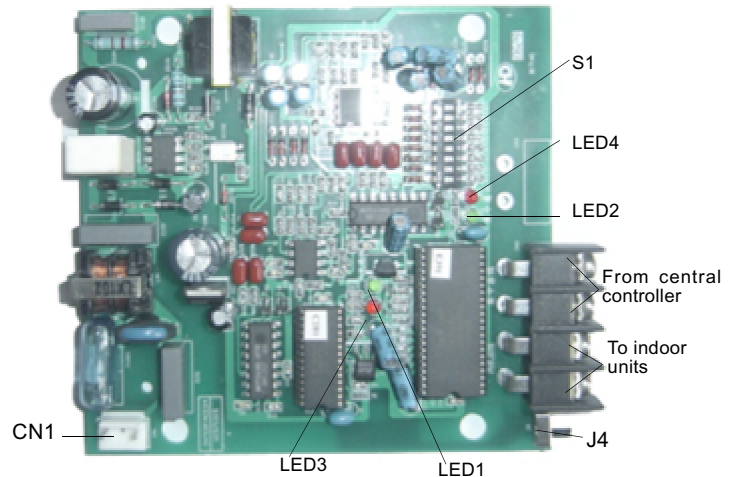
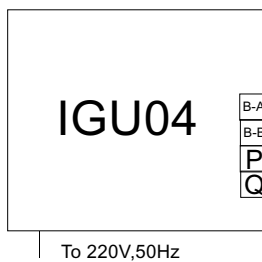

Caution: One central controller can control Up to 5 units of IGU04

2. Dip switch setting of connecting board ICR01

The dip switch is as below figure (ON:1, OFF: 0):

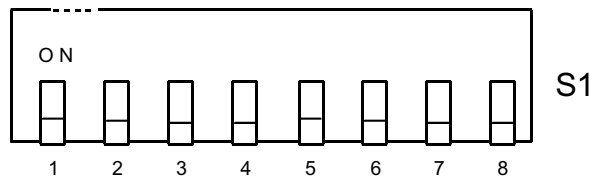

position								description
[1]	[2]	[3]	[4]	[5]	[6]	[7]	[8]	
*	*	0	0	0	0	0	0	connecting board address =1
*	*	0	0	0	0	0	1	connecting board address =2

*	*	0	1	1	1	1	0	connecting board address =63
*	*	0	1	1	1	1	1	connecting board address =64
*	0							central bus line: 3600baud
*	1							central bus line: 2400baud
1								manual set address

S1(3-8) is used to set IGU04 address, in one central control system, the address of IGU04 must be different.

12.3.Summarization

For installation information ,please refer central controller ICR01 manual , one ICR01 can control up to 5 sets of IGU04.



Большая библиотека технической документации

<https://splitsystema48.ru/instrukcii-po-ekspluatácii-kondicionerov.html>

каталоги, инструкции, сервисные мануалы, схемы.